

OPERATORS MANUAL MARINE DIESEL GENERATORS

8.0 EGTD - 60Hz	6.0 EGTD - 50Hz
10.0 EGTD - 60Hz	7.5 EGTD - 50Hz
11.0 EGTD - 60Hz	8.8 EGTD - 50Hz
11.5 EGTD - 60Hz	9.2 EGTD - 50Hz
12.5 EGTD - 60Hz	9.4 EGTD - 50Hz
15.0 EGTD - 60Hz	12.0 EGTD - 50Hz

**Electronically Governed
Single and Three Phase**

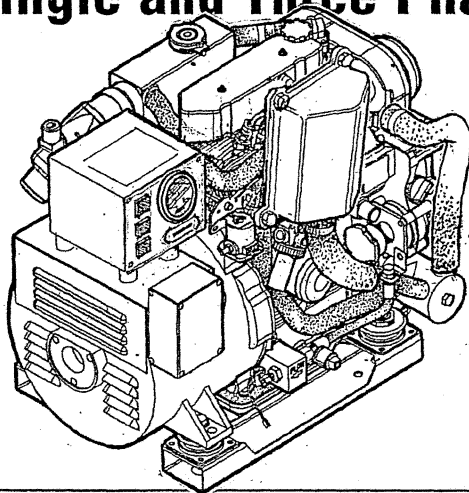

PUBLICATION NO. 056272 / REVISION 0 / DECEMBER 2016



WESTERBEKE CORPORATION • 150 JOHN HANCOCK ROAD
MYLES STANDISH INDUSTRIAL PARK • TAUNTON MA 02780
WEBSITE: WWW.WESTERBEKE.COM

**CALIFORNIA
PROPOSITION 65 WARNING**

Diesel engine exhaust and some of its constituents are known to the State of California to cause cancer, birth defects, and other reproductive harm.

⚠ WARNING:

Exhaust gasses contain Carbon Monoxide, an odorless and colorless gas. Carbon Monoxide is poisonous and can cause unconsciousness and death. Symptoms of Carbon Monoxide exposure can include:

- *Dizziness*
- *Nausea*
- *Headache*
- *Weakness and Sleepiness*
- *Throbbing in Temples*
- *Muscular Twitching*
- *Vomiting*
- *Inability to Think Coherently*

IF YOU OR ANYONE ELSE EXPERIENCE ANY OF THESE SYMPTOMS, GET OUT INTO THE FRESH AIR IMMEDIATELY. If symptoms persist, seek medical attention. Shut down the unit and do not restart until it has been inspected and repaired.



This WARNING DECAL is provided by WESTERBEKE and should be fixed to a bulkhead near your engine or generator.

WESTERBEKE also recommends installing CARBON MONOXIDE DETECTORS in the living/sleeping quarters of your vessel. They are inexpensive and easily obtainable at your local marine store.

SAFETY INSTRUCTIONS

INTRODUCTION

Read this safety manual carefully. Most accidents are caused by failure to follow fundamental rules and precautions. Know when dangerous conditions exist and take the necessary precautions to protect yourself, your personnel, and your machinery.

The following safety instructions are in compliance with the American Boat and Yacht Council (ABYC) standards.

PREVENT ELECTRIC SHOCK

⚠ WARNING: Do not touch AC electrical connections while engine is running. Lethal voltage is present at these connections!

- Do not operate this machinery without electrical enclosures and covers in place.
- Shut off electrical power before accessing electrical equipment.
- Use insulated mats whenever working on electrical equipment.
- Make sure your clothing and skin are dry, not damp (particularly shoes) when handling electrical equipment.
- Remove wristwatch and all jewelry when working on electrical equipment.

PREVENT BURNS — HOT ENGINE

⚠ WARNING: Do not touch hot engine parts or exhaust system components. A running engine gets very hot!

- Monitor engine antifreeze coolant level at the plastic coolant recovery tank and periodically at the filler cap location on the water jacketed exhaust manifold, but only when the engine is COLD.

⚠ WARNING: Steam can cause injury or death!

- In case of an engine overheat, allow the engine to cool before touching the engine or checking the coolant.

PREVENT BURNS — FIRE

⚠ WARNING: Fire can cause injury or death!

- Prevent flash fires. Do not smoke or permit flames or sparks to occur near the fuel injector, fuel line, filter, fuel pump, or other potential sources of spilled fuel or fuel vapors. Use a suitable container to catch all fuel when removing the fuel lines or fuel filters.
- Do not operate with the air cleaner/silencer removed. Backfire can cause severe injury or death.
- Do not smoke or permit flames or sparks to occur near the fuel system. Keep the compartment and the engine clean and free of debris to minimize the chances of fire. Wipe up all spilled fuel and engine oil.
- Be aware — diesel fuel will burn.

PREVENT BURNS — EXPLOSION

⚠ WARNING: Explosions from fuel vapors can cause injury or death!

- Follow re-fueling safety instructions. Keep the vessel's hatches closed when fueling. Open and ventilate the cabin after fueling. Check below for fumes/vapor before running the blower. Run the blower per four minutes before starting your engine.
- All fuel vapors are highly explosive. Use extreme care when handling and storing fuels. Store fuel in a well-ventilated area away from spark-producing equipment and out of the reach of children.
- Do not fill the fuel tank(s) while the engine while it is running.
- Shut off the fuel service valve at the engine when servicing the fuel system. Take care in catching any fuel that might spill. DO NOT allow any smoking, open flames, or other sources of fire near the fuel system or engine when servicing. Ensure proper ventilation exists when servicing the fuel system.
- Do not alter or modify the fuel system.
- Be sure all fuel supplies have a positive shutoff valve.
- Be certain fuel line fittings are adequately tightened and free of leaks.
- Make sure a fire extinguisher is installed nearby and is properly maintained. Be familiar with its proper use. Extinguishers rated ABC by the NFPA are appropriate for all applications encountered in this environment.

SAFETY INSTRUCTIONS

ACCIDENTAL STARTING

⚠ WARNING: Accidental starting can cause injury or death!

- Disconnect the battery cables before servicing the engine/generator. Remove the negative lead first and reconnect it last.
- Make certain all personnel are clear of the engine before starting.
- Make certain all covers, guards, and hatches are re-installed before starting the engine.

BATTERY EXPLOSION

⚠ WARNING: Battery explosion can cause injury or death!

- Do not smoke or allow an open flame near the battery being serviced. Lead acid batteries emit hydrogen, a highly explosive gas, which can be ignited by electrical arcing or by lit tobacco products. Shut off all electrical equipment in the vicinity to prevent electrical arcing during servicing.
- Never connect the negative (-) battery cable to the positive (+) connection terminal of the starter solenoid. Do not test the battery condition by shorting the terminals together. Sparks could ignite battery gases or fuel vapors. Ventilate any compartment containing batteries to prevent accumulation of explosive gases. To avoid sparks, do not disturb the battery charger connections while the battery is being charged.
- Avoid contacting the terminals with tools, etc., to prevent burns or sparks that could cause an explosion. Remove wristwatch, rings, and any other jewelry before handling the battery.
- Always turn the battery charger off before disconnecting the battery connections. Remove the negative lead first and reconnect it last when disconnecting the battery.

BATTERY ACID

⚠ WARNING: Sulfuric acid in batteries can cause severe injury or death!

- When servicing the battery or checking the electrolyte level, wear rubber gloves, a rubber apron, and eye protection. Batteries contain sulfuric acid which is destructive. If it comes in contact with your skin, wash it off at once with water. Acid may splash on the skin or into the eyes inadvertently when removing electrolyte caps.

TOXIC EXHAUST GASES

⚠ WARNING: Carbon monoxide (CO) is a deadly gas!

- Ensure that the exhaust system is adequate to expel gases discharged from the engine. Check the exhaust system regularly for leaks and make sure the exhaust manifolds are securely attached and no warping exists. Pay close attention to the manifold, water injection elbow, and exhaust pipe nipple.
- Be sure the unit and its surroundings are well ventilated.
- In addition to routine inspection of the exhaust system, install a carbon monoxide detector. Consult your boat builder or dealer for installation of approved detectors.
- For additional information refer to ABYC T-22 (educational information on Carbon Monoxide).

⚠ WARNING: Carbon monoxide (CO) is an invisible odorless gas. Inhalation produces flu-like symptoms, nausea or death!

- Do not use copper tubing in diesel exhaust systems. Diesel fumes can rapidly destroy copper tubing in exhaust systems. Exhaust sulfur causes rapid deterioration of copper tubing resulting in exhaust/water leakage.
- Do not install exhaust outlet where exhaust can be drawn through portholes, vents, or air conditioners. If the engine exhaust discharge outlet is near the waterline, water could enter the exhaust discharge outlet and close or restrict the flow of exhaust. Avoid overloading the craft.
- Although diesel engine exhaust gases are not as toxic as exhaust fumes from gasoline engines, carbon monoxide gas is present in diesel exhaust fumes. Some of the symptoms or signs of carbon monoxide inhalation or poisoning are:
 - Vomiting
 - Dizziness
 - Throbbing in temples
 - Muscular twitching
 - Intense headache
 - Weakness and sleepiness

AVOID MOVING PARTS

⚠ WARNING: Rotating parts can cause injury or death!

- Do not service the engine while it is running. If a situation arises in which it is absolutely necessary to make operating adjustments, use extreme care to avoid touching moving parts and hot exhaust system components.

SAFETY INSTRUCTIONS

- Do not wear loose clothing or jewelry when servicing equipment; avoid wearing loose jackets, shirts, sleeves, rings, necklaces or bracelets that could be caught in moving parts.
- Make sure all attaching hardware is properly tightened. Keep protective shields and guards in their respective places at all times.
- Do not check fluid levels or the drive belt's tension while the engine is operating.
- Stay clear of the drive shaft and the transmission coupling when the engine is running; hair and clothing can easily be caught in these rotating parts.

HAZARDOUS NOISE

 **WARNING: High noise levels can cause hearing loss!**

- Never operate an engine without its muffler installed.
- Do not run an engine with the air intake (silencer) removed.

 **WARNING: Do not work on machinery when you are mentally or physically incapacitated by fatigue!**

OPERATORS MANUAL

Many of the preceding safety tips and warnings are repeated in your Operators Manual along with other cautions and notes to highlight critical information. Read your manual carefully, maintain your equipment, and follow all safety procedures.

ENGINE AND GENERATOR INSTALLATIONS

Preparations to install an engine should begin with a thorough examination of the American Boat and Yacht Council's (ABYC) standards. These standards are a combination of sources including the USCG and the NFPA.

Sections of the ABYC standards of particular interest are:

- H-32 Ventilation for boats using diesel fuel
- H-33 Diesel Fuel Systems
- P-1 Installation of Exhaust Systems for Propulsion and Auxilliary Engines
- P-4 Marine Inboard Engines and Transmissions
- E-11 AC & DC Electrical Systems on Boats
- TA Batteries and Battery Chargers

All installations must comply with the Federal Code of Regulations (FCR).

ABYC, NFPA AND USCG PUBLICATIONS FOR INSTALLING MARINE ENGINES AND GENERATORS

Read the following ABYC, NFPA and USCG publications for safety codes and standards. Follow their recommendations when installing your UNIVERSAL engine

ABYC (American Boat and Yacht Council)
"Safety Standards for Small Craft"

Order From:

ABYC
613 Third Dstreet, Suite 10
Annapolis, MD 21403
(410) 990-4460
www.abycinc.org

NFPA (National Fire Protection Association)
"Fire Protection Standard for Motor Craft"

Order From:

NFPA
1 Batterymarch Park
P.O. Box 9101
Quincy, MA 02269-9101

USCG (United States Coast Guard)
"CFR 33 AND CFR46"
Code of Federal Regulations

Order From:

U.S. Government Printing Office
Washington, D.C. 20404

INSTALLATION

When installing WESTERBEKE engines and generators it is important that strict attention be paid to the following information:

CODES AND REGULATIONS

Strict federal regulations, ABYC guidelines, and safety codes must be complied with when installing engines and generators in a marine environment.

SIPHON-BREAK

For installations where the exhaust manifold/water injected exhaust elbow is close to or will be below the vessel's waterline, provisions must be made to install a siphon-break in the raw water supply hose to the exhaust elbow. This hose must be looped a minimum of 20" above the vessel's waterline. *Failure to use a siphon-break when the exhaust manifold injection port is at or below the load waterline will result in raw water damage to the engine and possible flooding of the boat.*

If you have any doubt about the position of the water-injected exhaust elbow relative to the vessel's waterline under the vessel's various operating conditions, *install a siphon-break.*

NOTE: *A siphon-break requires periodic inspection and cleaning to ensure proper operation. Failure to properly maintain a siphon-break can result in catastrophic engine damage. Consult the siphon-break manufacturer for proper maintenance.*

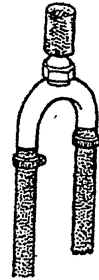

AVAILABLE FROM
YOUR WESTERBEKE
DEALER

SIPHON-BREAK WITH 2 INCHES
LOOP FOR 1" HOSE
PART NO. 044010

EXHAUST SYSTEM

The exhaust system's hose **MUST** be certified for marine use. Corrugated Marine Exhaust Hose is recommended. The use of this type of hose allows for extreme bends and turns without the need of additional fitting and clamps to accomplish these bends and turns. In this regard, a single length of corrugated exhaust hose can be used. The system **MUST** be designed to prevent the entry of water into the exhaust system under any sea conditions and at any angle of vessels heel.

A detailed Marine Installation Manual covering gasoline and diesel engines and generators is supplied with every unit sold. This manual is also available in pdf format on our website to download

Website: www.westerbeke.com

TABLE OF CONTENTS

Parts Identification	2	Engine Adjustments	28
Introduction	3	Glow Plugs	28
Diesel Fuel, Engine Oil and Coolant	5	Fuel Injectors	28
Preparations for Initial Start-Up	6	Valve Clearance	29
Generator Control Panel	7	Injection Timing	29
Operating Instructions	7	Generator Information	30
Remote Control Panels	8	Maintenance	30
Operating Instructions	8	BT Generator Description	31
Safety Shutdown Switches	9	Circuit Breaker	31
Generator Break-In Procedures	10	BT Generator - Single Phase	32
Daily Operation	10	Wiring Schematic	32
Maintenance Schedule (Chart)	11	Generator Voltage Adjustment	34
Cooling System	13	No-Load Adjustment	34
Changing Coolant	13	Full-Load Adjustment	35
Thermostat	14	BT Generator Internal Wiring	35
Raw Water Cooling	14	Three Phase/Twelve Wire	35
Raw Water Pump	15	BT Generator Internal Wiring	35
Intake Strainer	15	Three Phase/Twelve Wire	35
Heat Exchanger	15	Generator AC Voltage Connections	36
Zinc Anode	16	BE Three Phase	36
Air Intake/Silencer	16	BT Generator Single Phase	37
Filter Cartridge	16	Troubleshooting Chart	37
Fuel System	17	Optional Voltage Regulator	37
Fuel Water Separator	17	Shore Power Transfer Switch	38
Fuel Filter	17	Lay-Up and Recommissioning	39
Fuel Lift Pump	17	Specifications (Engine)	41
Engine Lubrication System	18	8.0 EGTD, 10.0 EGTD	42
Oil Change	18	11.5 EGTD, 11.0 EGTD	43
Oil Filter	18	Specifications (Engine)	44
Oil Pressure	19	12.5 EGTD, 15.0 EGTD	45
Testing Oil Pressure	19	Wiring Diagram #56225	46
Remote Oil Filter	20	Wiring Schematic #56225	47
DC Electrical System	21	Wiring Diagram #56321	48
Alternator	21	Remote Start/Stop Panel	48
Alternator Troubleshooting	21	Water Heater (Optional)	49
Battery Care	22	Power Take-Off (Optional)	50
Starter Motor	23	Raw Water Discharge Hose	51
Troubleshooting	24	Engine Torque Specifications	52
Engine Troubleshooting	25	Suggested Spare Parts	52
LED/Shutdown (Chart)	25		
Engine Troubleshooting (Chart)	26		
Water and Oil Pressure Gauges	27		

EGTD PARTS IDENTIFICATION

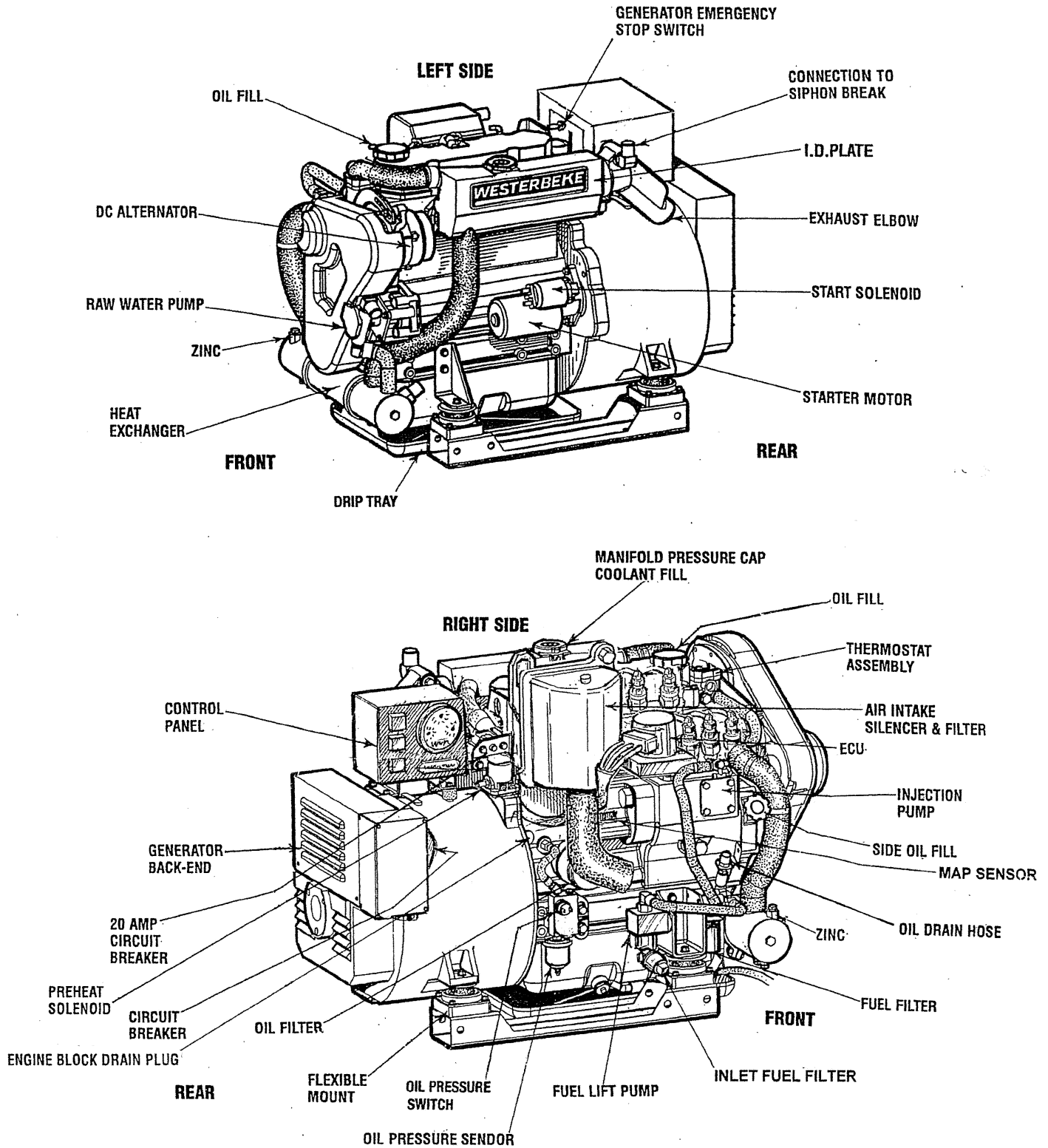

INTRODUCTION

This WESTERBEKE Diesel Generator is a product of WESTERBEKE's long years of experience and advanced technology. We take great pride in the superior durability and dependable performance of our engines and generators. Thank you for selecting WESTERBEKE.

In order to get the full use and benefit from your generator it is important that you operate and maintain it correctly. This manual is designed to help you do this. Please, read this manual carefully and observe all the safety precautions throughout. Should your generator require servicing, contact your nearest WESTERBEKE dealer for assistance.

This is your operators manual. Along with this manual, there is an Installation Manual and Parts Information. A Service Manual is available in pdf form on our website or can be ordered in book form from a WESTERBEKE/UNIVERSAL Dealer

WARRANTY PROCEDURES

Your WESTERBEKE Warranty Statement is included in the product documentation package. There is a Warranty Registration Card you can fill out and mail to Westerbeke Corporation or go to our website: www.westerbeke.com and register your products warranty on line. You should receive a Customer Identification card in the mail within 60 days of registering. If you do not, please contact the factory and have your product model number, serial number and in service date available.

Customer Identification Card

 WESTERBEKE Engines & Generators	
Customer Identification	
MR. GENERATOR OWNER	
MAIN STREET	
HOMETOWN, USA	
Model _____	Serial # _____
Expires _____	

NOTES, CAUTIONS AND WARNINGS

As this manual takes you through the operating procedures, maintenance schedules, and troubleshooting of your marine engine, critical information will be highlighted by NOTES, CAUTIONS, and WARNINGS. An explanation follows:

NOTE: An operating procedure essential to note.

CAUTION: Procedures, which if not strictly observed, can result in the damage or destruction of your engine.

WARNING: Procedures, which if not properly followed, can result in personal injury or loss of life.

PRODUCT SOFTWARE

Product software, (tech data, parts lists, manuals, brochures and catalogs), provided from sources other than WESTERBEKE are not within WESTERBEKE's control.

WESTERBEKE CANNOT BE RESPONSIBLE FOR THE CONTENT OF SUCH SOFTWARE, MAKES NO WARRANTIES OR REPRESENTATIONS WITH RESPECT THERETO, INCLUDING ACCURACY, TIMELINESS OR COMPLETENESS THEREOF AND WILL IN NO EVENT BE LIABLE FOR ANY TYPE OF DAMAGE OR INJURY INCURRED IN CONNECTION WITH OR ARISING OUT OF THE FURNISHING OR USE OF SUCH SOFTWARE.

WESTERBEKE customers should also keep in mind the time span between printings of WESTERBEKE product software and the unavoidable existence of earlier WESTERBEKE manuals. In summation, product software provided with WESTERBEKE products, whether from WESTERBEKE or other suppliers, must not and cannot be relied upon exclusively as the definitive authority on the respective product. It not only makes good sense but is imperative that appropriate representatives of WESTERBEKE or the supplier in question be consulted to determine the accuracy and currentness of the product software being consulted by the customer.

PROTECTING YOUR INVESTMENT

Care at the factory during assembly and thorough testing have resulted in a WESTERBEKE generator capable of many thousands of hours of dependable service. However the manufacturer cannot control how or where the generator is installed in the vessel or the manner in which the unit is operated and serviced in the field. This is up to the buyer/owner-operator.

NOTE: Six important steps to ensure long generator life:

- Proper engine and generator installation and alignment.
- An efficient well-designed exhaust system that includes an anti-siphon break to prevent water from entering the engine.
- Changing the engine oil and oil filters according to the maintenance schedule.
- Proper maintenance of all engine and generator components according to the maintenance schedule in this manual.
- Use clean, filtered #2 diesel fuel.
- Winterize your engine according to the "Lay-up and Recommissioning" section in this manual.

INTRODUCTION

SERIAL NUMBER LOCATION

The engine's model and serial number are located on a nameplate mounted on the side of the water jacketed exhaust manifold.

The engine's serial number is also found stamped in the engine block on a flat surface just above the the side oil fill opening. Take time to enter this information below on the illustrated nameplate.

SPECIFICATION	50 HZ.	60 HZ.
MODEL		
RPM		
KW		
KVA		
VOLTS		
AMPS		
ENG. HP		
ENG. SER. NO.		
GEN. SER. NO.		
PF/PHASE	/	
WIRES		
RATING		
INSUL. CLASS		
TEMP. RISE		
BATTERY		
C.I.D.		



An identification plate on the top of the engine air intake also displays the engine model and serial number.

CARBON MONOXIDE DETECTOR

WESTERBEKE recommends mounting a carbon monoxide detector in the vessels living quarters. Carbon monoxide, even in small amounts, is deadly.

The presence of carbon monoxide indicates an exhaust leak from the engine or generator or from the exhaust elbow/exhaust hose, or the fumes from a nearby vessel are entering your boat.

If carbon monoxide is present, ventilate the area with clean air and correct the problem immediately!

NOTE: A carbon monoxide warning decal has been provided by WESTERBEKE. Affix this decal in a visible position in the engine room.

UNDERSTANDING THE DIESEL ENGINE

The diesel engine closely resembles the gasoline engine, since the mechanism is essentially the same. The cylinders are arranged above a closed crankcase; the crankshaft is of the same general type as that of a gasoline engine; and the diesel engine has the same types of valves, camshaft, pistons, connecting rods and lubricating system.

Therefore, to a great extent, a diesel engine requires the same preventive maintenance as a gasoline engine. The most important factors are proper ventilation and proper maintenance of the fuel, lubricating and cooling systems. Replacement of fuel and lubricating filter elements at the time periods specified is a must, and frequent checking for contamination (that is, water, sediment, etc.) in the fuel system is also essential. Another important factor is the use of the same brand of high detergent diesel lubrication oil designed specifically for diesel engines.

The diesel engine does differ from the gasoline engine, however, in its method of handling and firing of fuel. The carburetor and ignition systems are done away with and in their place is a single component – the fuel injection pump which performs the function of both.

ORDERING PARTS

Whenever replacement/service parts are needed, always provide the generator model number, engine serial number, and generator serial number as they appear on the silver and black name plate located on the generator end. You must provide us with this information so we may properly identify your generator set. In addition, include a complete part description and part number for each part needed (see the separately furnished Parts List). Also insist upon WESTERBEKE packaged parts because *will fit* or generic parts are frequently not made to the same specifications as original equipment.

SPARES AND ACCESSORIES

Certain spares will be needed to support and maintain your WESTERBEKE generator. Your local WESTERBEKE dealer will assist you in preparing an inventory of spare parts. See the *SPARE PARTS* page in this manual. For Engine and Generator Accessories, see the *ACCESSORIES* brochure.

INSTALLATION MANUAL

The Westerbeke Installation Manual publication #043268 is supplied with this unit.

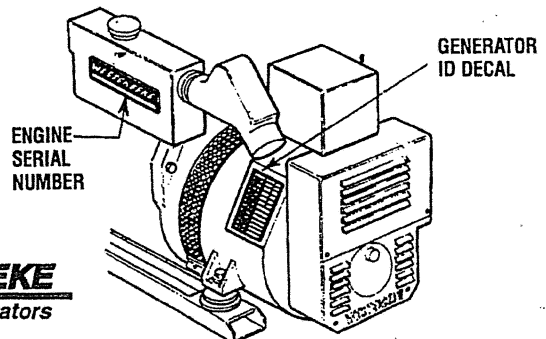

DIESEL FUEL, ENGINE OIL AND ENGINE COOLANT

DIESEL FUEL

Use a diesel fuel that meets the requirements of No. 2-D SAE J 313 and has a Cetane rating of #45 or higher grade of diesel fuel according to ASTM D975.

Care Of The Fuel Supply

Use only clean diesel fuel! The clearance of the components in your engines fuel injection pump is very critical; invisible dirt particles which might pass through the primary and secondary filters can damage these finely machined parts. It is important to buy clean fuel, and keep it clean. The best fuel can be rendered unsatisfactory by careless handling or improper storage facilities. To assure that the fuel going into the tank for your engine's daily use is clean and pure, the following practice is advisable:

Purchase a well-known brand of fuel. The use of additives to combat BACTERIAL growth on the fuel tank is recommended such as Bio-Bor and an additive such as *Diesel Kleen + Cetane Boost* to help restore lubricity back into the diesel fuel when an Ultra Low Sulfur diesel is being used.

Install and regularly service a good, visual-type fuel filter/water separator between the fuel tank and the engine. The Raycor 500 MA or 230 RMAM are good examples of such filters. A 10 micron filter element is recommended.

ENGINE OIL

Use a good brand of engine oil having an API and SAE specification as stated in the SPECIFICATIONS section in this manual. Change the engine oil and oil filter after the initial 50 hours of engine break-in operation and then every 100 hours of operation thereafter.

Westerbeke Corporation does not approve or disapprove the use of synthetic oils. If synthetic oils are used, engine break-in must be performed using conventional oil. Oil change intervals must be as listed in the MAINTENANCE SCHEDULE section of this manual and not be extended if synthetic oils are used.

NOTE: *The information above supersedes all previous statements regarding synthetic oil.*

SAE OIL VISCOSITY GRADES

For all temperatures ranges: SAE 10W-40 or 15W-40.

ENGINE COOLANT

WESTERBEKE recommends a mixture of 50% antifreeze and 50% distilled water. Distilled water is free from the chemicals that can corrode internal engine surfaces.

The antifreeze performs double duty. It allows the engine to run at proper temperatures by transferring heat away from the engine to the coolant, and lubricates and protects the cooling circuit from rust and corrosion. Look for a good quality antifreeze that contains Supplemental Cooling Additives (SCAs) that keep the antifreeze chemically balanced, crucial to long term protection.

The distilled water and antifreeze should be premixed before being poured into the cooling circuit.

NOTE: *Look for the new environmentally-friendly long lasting antifreeze that is now available.*

PURCHASING ANTIFREEZE

Select a brand of antifreeze specified for diesel engines. Antifreeze specified for diesel engines contains a special additive to protect against cavitation erosion of the engine's cylinder walls. Prestone and Zerex are two nationally known brands that offer antifreeze specifically for use in diesel engines. Select the pre-mixed variety so that the correct mixture will always be added to the cooling system when needed. Change the antifreeze mixture according to the MAINTENANCE SCHEDULE in this manual.

MAINTENANCE

Change the engine coolant every five years regardless of the number of operating hours as the chemical additives that protect and lubricate the engine have a limited life.

COOLANT RECOVERY TANK

The coolant recovery allows for the expansion and contraction of the engines coolant during engine operation without introducing air into the system. This recovery tank is provided with fresh water cooled models and with the fresh water coolant conversion kit and must be installed before operating the engine.

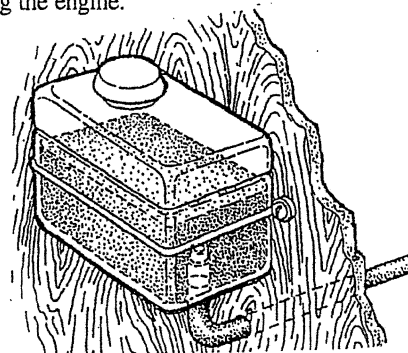

NOTE: *This tank, with its short run of plastic hose, is best located at or above the level of the engine's manifold, but it can be located below the level of the engine's manifold if the particular installation makes this necessary.*

PREPARATIONS FOR INITIAL START-UP

PRESTART INSPECTION

Before starting your generator set for the first time or after a prolonged layoff, check the following items:

- Make certain the cooling water thru-hull is open.
- Check the engine oil level. Add oil to maintain the level at the full mark on the dipstick.
- Check the fuel supply and examine the fuel filter/separator bowls for contaminants.
- Check the DC electrical system. Inspect wire connections and battery cable connections.
- Check load leads for correct connection as specified in the wiring diagrams.
- Examine air inlet and outlet for air flow obstructions (SoundGuards).
- Be sure no other generator or utility power is connected to load lines.
- Be sure that in power systems with a neutral line that the neutral is properly grounded (or ungrounded) as the system requires, and that the generator neutral is properly connected to the load neutral. In single phase systems an incomplete or open neutral can supply the wrong line-to-neutral voltage on unbalanced loads.
- Visually examine the unit. Look for loose or missing parts, disconnected wires, unattached hoses, and check threaded connections. Search for any fuel line leaks.

CAUTION: When starting the generator, it is recommended that all AC loads, especially large motors, be switched OFF until the engine has come up to speed and, in cold climates, starts to warm up. This precaution will prevent damage caused by unanticipated operation of the AC machinery and will prevent a cold engine from stalling.

- Check the coolant level in both the plastic recovery tank and at the manifold.

NOTE: After the initial running of the generator, the air in the engine's cooling system will be purged to the coolant recovery tank. Open the air bleed petcock to ensure that the cooling system is purged of air. After shutdown and after the engine has cooled, the coolant from the recovery tank will be drawn into the engine's cooling system to replace the purged air.

Before subsequent operation of the generator, the engine's manifold should be topped off, and the coolant recovery tank may need to be filled to the MAX level.

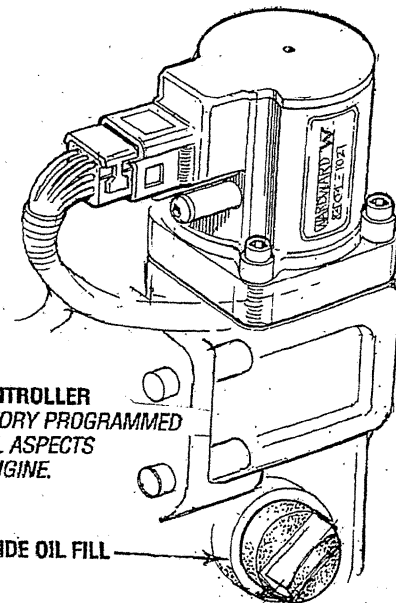
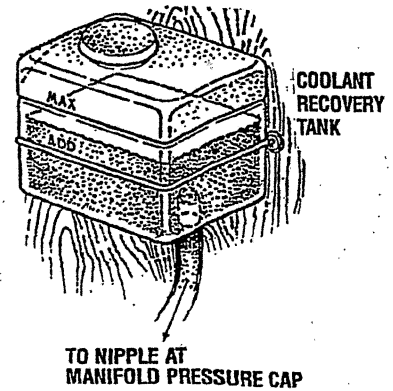
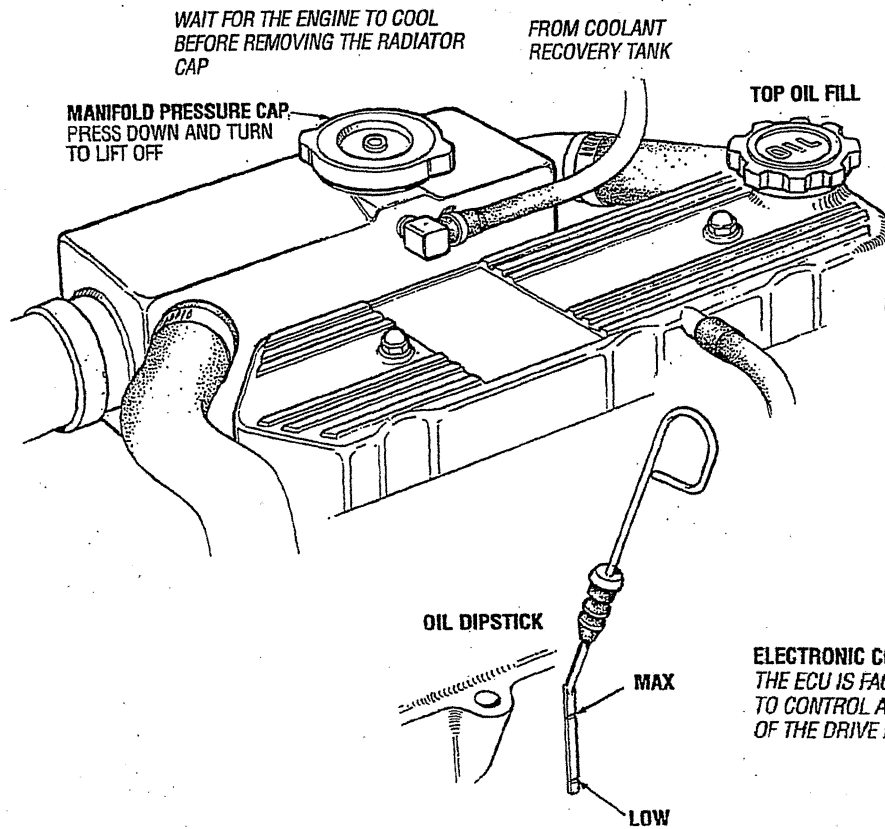

GENERATOR INSTRUMENT CONTROL PANEL

OPERATING INSTRUCTIONS

DESCRIPTION

The Generators Instrument Control contains a compact gauge package, control rocker switches, circuit fuses, check engine light, emergency stop toggle switch and a recording hourmeter. These components are described below.

The 8 pin connector that is on the back of the Control Box is used to connect an optional remote start/stop panel or a second instrument panel.

When an optional panel is connected, the 8 pin connector with jumper should be kept for future needs when troubleshooting. Secure it to the lifting eye.

FUSES: The control box has two automotive type fuses. A 5 amp fuse protects the ECU and a 7.5 amp fuse to protect the control circuit and instrument panel.

CHECK ENGINE LIGHT: The CHECK ENGINE LIGHT will illuminate if the engine shuts down. (Refer to the Safety Shutdown in this manual).

EMERGENCY STOP: The EMERGENCY stop toggle switch (Normally Closed) is located at the side of the control box. When depressed, it will open the DC circuit to the control box. This switch can be used when servicing the unit to prevent an unwanted start.

REMOTE PANEL PLUG-IN: A plug on the side on the control box will allow for the remote mounting of the remote instrument panel or the remote panel start/stop.

COOLANT TEMPERATURE: Engine coolant (water) temperature should normally indicate: 175° to 195°F (80° to 90°C).

ENGINE OIL PRESSURE: Oil Pressure (psi) may fluctuate depending on the generator load but should range between 35 to 55 psi.

DC VOLTS: Indicates the amount the battery is being charged and should show 13V to 14V.

HOURLMETER: Registers elapsed time and is used as a guide for when to perform scheduled maintenance.

PREHEAT: The PREHEAT rocker switch serves two purposes: activates the preheat circuit and activates the K2 Run Relay. This supplies power to the DC alternator R, fuel pump, ECU, Instrument panel, K3 Fault Relay pin #87 and Start toggle switch.

START: The START rocker switch when pressed activates the K1 Start Relay which activates the starter motor.

STOP: The STOP rocker switch when pressed and held, opens the DC circuit supplying power to the K2 Run relay. De-activating it and shutting down the engine drive.

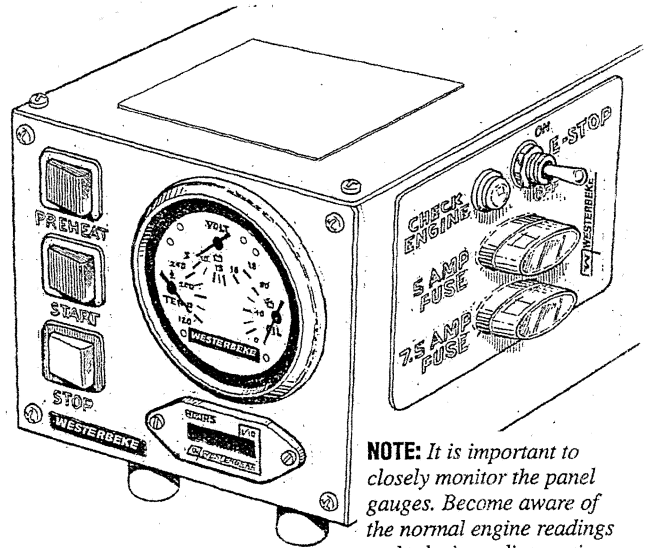

THIS PANEL CAN ALSO BE REMOTELY LOCATED, REFER TO THE FOLLOWING PAGE

NOTE: It is important to closely monitor the panel gauges. Become aware of the normal engine readings and take immediate action if these readings start to vary.

STARTING/STOPPING INSTRUCTIONS

Depress the PREHEAT rocker switch for approximately 5-10 seconds. Then with the PREHEAT rocker still depressed, depress the START rocker. When the engine starts, release the START rocker.

Remote Control Panel: When the oil and voltmeter start to register, release the Start rocker.

Continue to hold the PREHEAT rocker depressed until the oil pressure reaches 10 psi. Then release the PREHEAT rocker.

Once the generator has started, observe the meter readings on the instrument panel. Ensure that raw water is being discharged with the exhaust. Apply a light amperage load on the generator and allow it to warm up to 140°F, then apply your higher amperage loads as needed.

FAILURE TO START: Should the engine not start after the START rocker has been depressed for 5-10 seconds, release both rocker switches and wait 30 seconds and repeat the above start procedure. Preheat a few seconds longer. Never run the starter continually for more than 20-25 seconds.

STOPPING: To stop the generator, depress the STOP rocker and hold it depressed. Release the STOP rocker when the generator comes to a complete stop.

REMOTE CONTROL PANEL: Release the STOP rocker when the oil and voltmeter stop registering.

OPTIONAL REMOTE CONTROL PANELS

OPERATING INSTRUCTIONS

DESCRIPTION

There are several options available when selecting remote operation of your generator.

1. Mount a second (repeating) Instrument Control Panel in a remote location.
2. Simply remove the Instrument Control Panel from the control box and mount it as a remote panel.

NOTE: *The Instrument Control Panel can be replaced by installing a basic start/stop panel in the control box.*

3. Mount a remote start/stop control panel in a remote location.

Remote panels connect to the 8 pin plug on the back of the control box using the extension harnesses listed below.

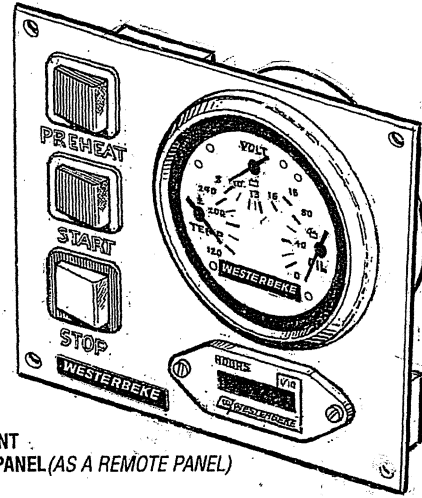

INSTRUMENT
CONTROL PANEL (AS A REMOTE PANEL)
PN 56246

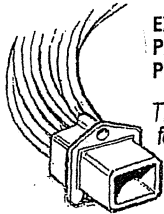

EXTENSION HARNESS
PN#056236 EG DIESEL (8 PIN) 15FT
PN#056235 EG DIESEL (8 PIN) 30FT

These extension harnesses are for either of these Remote Panels.

NOTE: When connecting a remote panel to the plug connector on the back of the control box, **DO NOT** discard the plug with jumper found in this plug connector. Keep it with the unit. Attach it to the rear lifting eye. It will be useful in troubleshooting a DC/running issue by eliminating the remote panel and returning this plug with jumper to the connector.

REMOTE START/STOP PANEL - DESCRIPTION

The Remote Start/Stop Panel has the same three rocker switches as the Instrument Control Panel. Their function is the same. This panel has a RELEASE STARTER LED. This LED will illuminate when the PREHEAT is depressed. When this panel is remote mounted, this LED will indicate when the generator has started. When depressing the START rocker switch, this LED will dim. When the generator starts, the LED will brighten. This indicates to release the START rocker switch. The PREHEAT rocker switch is held depressed for about 4-5 seconds to allow the oil pressure to reach 10 psi, then release it.

For the REMOTE START/STOP PANEL wiring diagram and wiring harness, refer to the Table of Contents.

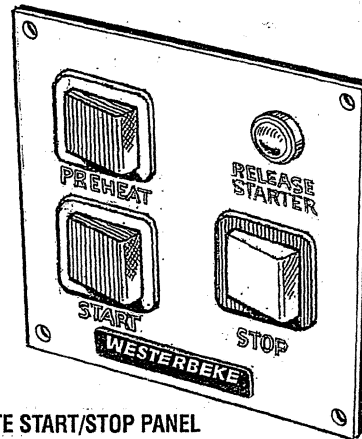

REMOTE START/STOP PANEL
PN 56320

SAFETY SHUTDOWN SWITCHES

DESCRIPTION

The engine is protected by a number of safety shutdown features as described below. Should a shutdown occur, as a result of one of these features, the **Check Engine LED** will illuminate. The cause should be determined using the troubleshooting **Diagnostic Software**. Once corrected, the ECU must be cleared of this fault by turning OFF the 20 amp DC breaker and then back ON in order to start the engine.

High Exhaust Temperature Switch

An exhaust temperature switch is located on the exhaust elbow. Normally closed, this switch will open and interrupt the DC voltage to the K2 relay (shutting OFF the engine) should the switch's sensor indicate an excessive exhaust temperature (an inadequate supply of raw water causes high exhaust temperatures). This switch opens at 260-270°F (127-132°C). This switch resets at approximately 225°F (107°C).

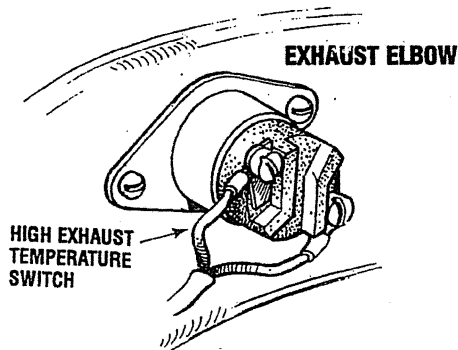

Coolant Temperature Switch

A high coolant temperature switch is located on the thermostat housing. Normally closed, this switch, should the fresh water coolant's operating temperature reach approximately 210°F (99°C), will open and interrupt the DC voltage to the K2 relay, thereby shutting off the engine. This switch resets at 195°F (107°C).

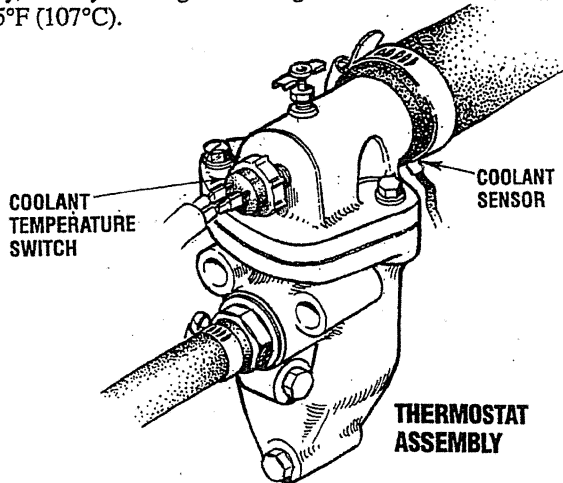

Low Oil Pressure Switch

A low oil pressure shutdown switch is located off the engine's oil gallery. Normally open in a static state, this switch's sensor monitors the engine's oil pressure. Should the engine's oil pressure fall to 5-10 psi, this switch will open interrupting the DC voltage to the K2 relay, thereby shutting off the engine.

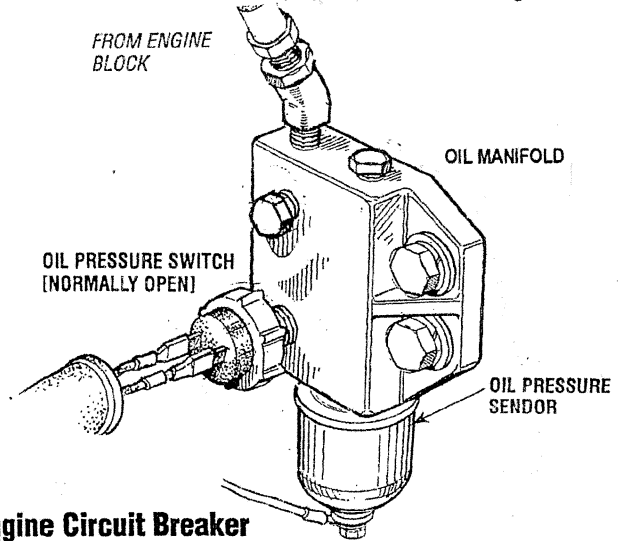

Engine Circuit Breaker

The generator's engine is protected by an engine mounted manual reset circuit breaker (20 amps DC). Excessive current draw or electrical overload anywhere in the instrument panel wiring or engine wiring will cause the breaker to trip. In this event the generator will shut down and the voltage to the K2 relay is terminated. If this should occur, check and repair the source of the problem. After repairing the fault, reset the breaker and restart the generator.

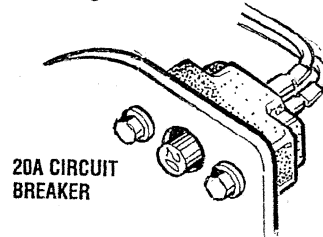

Overspeed/Underspeed Shutdown

The unit's ECU is monitoring the engine speed via a signal from the MPU (magnetic pick-up) positioned over the fly wheel's ring gear teeth. Should the engine speed reach a programmed high rpm or low rpm, the ECU will shut the engine down and the **Check Engine LED** will illuminate.

GENERATOR BREAK-IN PROCEDURE

DESCRIPTION

Although your engine has experienced a minimum of one hour of test operations at the factory to make sure accurate assembly procedures were followed and that the engine operated properly, a break-in time is required. The service life of your engine is dependent upon how the engine is operated and serviced during its initial hours of use.

Breaking-in a new engine basically involves seating the piston rings to the cylinder walls. Excessive oil consumption and smoky operation indicate that the cylinder walls are scored, which is caused by overloading the generator during the break-in period.

Your new engine requires approximately 50 hours of initial conditioning operation to break in each moving part in order to maximize the performance and service life of the engine.

AFTER START-UP

Once the generator has been started, check for proper operation and then encourage a fast warm-up. Run the generator between 20% and 60% of full-load for the first 10 hours.

CAUTION: Do not attempt to break-in your generator by running without a load.

After the first 10 hours of the generator's operation, the load can be increased to the full-load rated output, then periodically vary the load.

Avoid overload at all times. An overload is signaled by smoky exhaust with reduced output voltage and frequency. Monitor the current being drawn from the generator and keep it within the generator's rating. Since the generator operates at 1800 rpm to produce 60 hertz (or at 1500 rpm to produce 50 Hertz), control of the generator's break-in is governed by the current drawn from the generator.

GENERATOR ADJUSTMENTS

Once the generator has been placed in operation, there may be adjustments required for engine speed (hertz) during the engine's break-in period (first 50 hours) or after this period. A no-load voltage adjustment may also be required in conjunction with the engine's speed adjustment. See *GENERATOR INFORMATION* in this manual.

THE DAILY OPERATION

CHECK LIST

Follow this check list each day before starting your generator.

- Check that all generator circuit breakers (power panel) are in the off position before starting.
- Record the hourmeter reading in your log (engine hours relate to the maintenance schedule.)
- Visually inspect the engine for fuel, oil, or water leaks.
- Check the oil level (dipstick).
- Check the coolant level in the coolant recovery tank.
- Check your fuel supply.
- Check the starting batteries (weekly).
- Check drive belts for wear and proper tension (weekly).

CHECK WITH THE ENGINE RUNNING.

- Check for abnormal noise such as knocking, vibrating and blow-back sounds.
- Confirm exhaust smoke:
When the engine is cold - White Smoke.
When the engine is warm - almost Smokeless.
When the engine is overloaded - some Black Smoke.

START THE GENERATOR

(See *STARTING PROCEDURES* on previous pages). Allow the engine to warm up for 5 to 10 minutes to reach an operating temperature of 140° to 150°F (60°-66°C) before applying AC loads. Apply loads systematically allowing the generator to adjust to each load before applying the next. Check the gauges for proper oil pressure, operating temperature, and DC voltage.

NOTE: Some unstable running may occur in a cold engine. This condition should lessen as normal operating temperature is reached and loads are applied.

CAUTION: Do not operate the generator for long periods of time without a load being placed on the generator.

STOPPING THE GENERATOR

Remove the major AC loads from the generator one at a time. Allow the generator to run for a few minutes to stabilize the operating temperature and depress the stop switch. (See *STOPPING PROCEDURES* on previous pages.)

MAINTENANCE SCHEDULE

WARNING: *Never attempt to perform any service while the engine is running. Wear the proper safety equipment such as goggles and gloves, and use the correct tools for each job. When servicing/replacing DC components, turn off the Emergency Stop Switch on the Control Box or turn off the DC battery.*

SCHEDULED MAINTENANCE

EXPLANATION OF SCHEDULED MAINTENANCE

Maintenance procedures are all detailed in this manual.

DAILY CHECK BEFORE START-UP

Coolant Level	Check at recovery tank, if empty, check at manifold. Add coolant if needed.
Engine Oil Level	Oil level should indicate between MAX and LOW on dipstick. Do not overfill!
Fuel/Water Separator (owner installed)	Check for water and dirt in fuel. Drain filter if necessary. Replace filter every 250 operating hours or once a year.
Fuel Supply	Use properly filtered #2 diesel with a Cetane rating of #45 or higher. Check that there is adequate fuel for the vessel's needs.
Visual Inspection of Engine <i>NOTE: Please keep engine surface clean. Dirt and oil will inhibit the engine's ability to remain cool.</i>	Check for fuel, oil and water and exhaust leaks. Check that the water injected exhaust elbow securing v-clamp is tight. No exhaust leaks around the elbow. Inspect wiring and electrical connections. Look for loose bolts/hardware and correct as needed.
Drive Belts	Inspect for frayed edges. Belts must be properly tensioned .

INITIAL 50 HOURS OF OPERATION

Engine Oil and Filter	Initial engine oil and filter change at 50 hours.
*Exhaust System	Check security of water injected exhaust elbow to exhaust manifold. Ensure there are no leaks.
*Valve Adjustment	Check adjustment of valves.
*Re-Torque Cylinderhead Hold Down Bolts	Re-torque bolts, engine cold then check/adjust valve clearances.
Inlet Fuel Filter	Remove and replace inlet fuel filter.
Fuel Filter	Remove and replace fuel filter and all sealing O-rings.
Generator	Check that AC connections are secure with no chafing.
AC No-Load	Check and adjust the no-load AC output voltage as needed.

EVERY 50 OPERATING HOURS OR MONTHLY

Drive Belt	Inspect for proper tension (3/8" to 1/2" deflection) and adjust if needed. Check belt for slipping, cracking and wear. Adjust tension or replace as needed. Replace cover.
Starting Batteries	Check electrolyte levels. Make sure cables and connections are in good order. Clean off corrosion if needed. Apply petroleum jelly to terminals for corrosion protection.
Electric Fuel Pump	Inspect for leaks, ensure fuel and electrical connections are clean and tight.
Zinc Anode	Inspect and clean zinc anode. Replace if necessary. Note the condition, then determine your own inspection schedule.

EVERY 100 OPERATING HOURS OR YEARLY

Engine Oil and Filter	Change engine oil and filter at 100 operating hours or yearly..
Air Intake and Filter	Keep air intake clear of obstructions. Clean air filter and replace if needed .

*WESTERBEKE recommends this service be performed by an knowledgeable mechanic.

MAINTENANCE SCHEDULE

NOTE: Use the engine hourmeter gauge to log your engine hours or record your engine hours running time.

SCHEDULED MAINTENANCE

EXPLANATION OF SCHEDULED MAINTENANCE

EVERY 250 OPERATING HOURS OR YEARLY

*Exhaust Elbow/Exhaust System	Check the structural integrity of the water injected exhaust elbow casting. Check the integrity of the exhaust system attached to the elbow. All hose connections should be secure. No chaffing. No exhaust leaks. Hoses and muffler are in good serviceable condition. NOTE: An exhaust leak will cause exposure to diesel exhaust!
Fuel Filter and O-Rings	Remove and replace fuel filter and all sealing O-rings.
Inlet Fuel Filter	Remove and replace inlet fuel filter.
*Generator	Check that AC connections are clean and secure. Ensure wires have no chafing. See <i>GENERATOR INFORMATION</i> .
Hoses	Engine hoses should be firm and tight. Replace if hoses become spongy, brittle or delaminated. Check and tighten all hose clamps as needed.
Fuel Water Separator Filter	Inspect bowl for dirt or water in fuel. Drain and replace filter.
DC Alternator	Inspect wiring, connections should be tight. Alternator should be clean and free of corrosion. Check mounting bracket and alternator bolt. All should be tight.
Impeller	Inspect the condition of the impeller, replace as needed.

EVERY 500 OPERATING HOURS OR FIVE YEARS

Raw Water Pump	Remove and disassemble the pump and inspect all parts: drive gear, pump shaft, wear plate and cover for wear and corrosion. Replace the impeller and gasket. Lubricate the impeller at re-assembly.
Coolant System	Drain, flush and re-fill the cooling system with appropriate antifreeze mix. Inspect the condition of the sealing gaskets of the pressure cap. Clean out coolant recovery tank and connecting hose.
*Valve Clearances	Adjust valves. (Incorrect valve clearance will result in poor engine performance.)
*Starter Motor	Check solenoid and motor for corrosion. Remove and lubricate. Clean and lubricate the starter motor pinion drive.
*Re-Torque Cylinderhead Hold Down Bolts	Re-torque bolts, engine cold then check/adjust valve clearances.
Pre-Heat Circuit	Check operation of preheat solenoid. Remove glow plugs, clean tips and check operation.
Fuel Injectors	Check and adjust injection opening pressure and spray conditions.

EVERY 1000 OPERATING HOURS OR OR EVERY FIVE YEARS

Heat Exchanger	Remove the heat exchanger for professional cleaning and pressure testing.
*MPU (Magnetic Pick-Up)	Remove, check and clean any metal debris from the tip of the MPU.

*WESTERBEKE recommends this service be performed by an knowledgeable mechanic.

COOLING SYSTEM

DESCRIPTION

Westerbeke marine diesel engines are designed and equipped for fresh water cooling. Heat produced in the engine by combustion and friction is transferred to fresh water coolant which circulates throughout the engine. This circulating fresh water coolant cools the engine block, its internal moving parts, and the engine oil. The heat is transferred externally from the fresh water coolant to raw water by means of a heat exchanger, similar in function to an automotive radiator. Raw water flows through the tubes of the heat exchanger while fresh water coolant flows around the tubes; engine heat transferred to the fresh water coolant is conducted through the tube walls to the raw water which is then pumped into the exhaust system where finally it is discharged overboard. In other words, the engine is cooled by fresh water coolant, this coolant is cooled by raw water, and the raw water carries the transferred heat overboard through the exhaust system. The fresh water coolant and raw water circuits are independent of each other. Using only fresh water coolant within the engine allows the cooling water passages to stay clean and free from harmful deposits.

FRESH WATER COOLING CIRCUIT

NOTE: Refer to the *ENGINE COOLANT* section for the recommended antifreeze and water mixture to be used as the fresh water coolant.

Fresh water coolant is pumped through the engine by a circulating pump, absorbing heat from the engine. The coolant then passes through the thermostat into the manifold, to the heat exchanger where it is cooled, and returned to the engine block via the suction side of the circulating pump.

When the engine is started cold, external coolant flow is prevented by the closed thermostat (although some coolant flow is bypassed around the thermostat to prevent the exhaust manifold from overheating). As the engine warms up, the thermostat gradually opens, allowing full flow of the engine's coolant to flow unrestricted to the external portion of the cooling system.

Coolant Recovery Tank

A coolant recovery tank allows for engine coolant expansion and contraction during engine operation, without any significant loss of coolant and without introducing air into the cooling system. This tank should be located at or above the engine manifold level and should be easily accessible.

CHANGING COOLANT

The engine's coolant must be changed according to the *MAINTENANCE SCHEDULE*. If the coolant is allowed to become contaminated, it can lead to overheating problems.

CAUTION: Proper cooling system maintenance is critical; a substantial number of engine failures can be traced back to cooling system corrosion.

Drain the engine coolant by loosening the drain plug on the engine block and opening the manifold pressure cap. Flush the system with fresh water, then start the refill process.

NOTE: The drain petcock on the heat exchanger should also be used to help drain engine coolant.

WARNING: Beware of the hot engine coolant. Wear protective gloves.

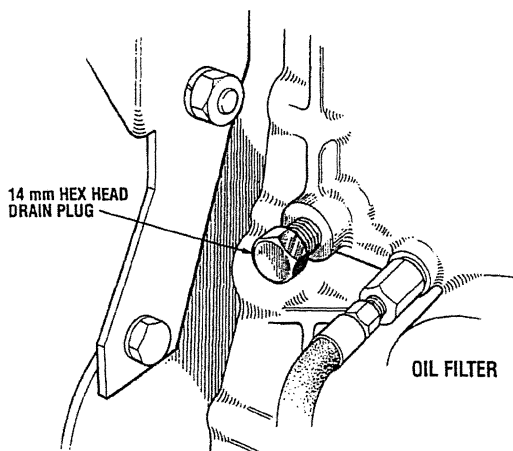

ENGINE BLOCK COOLANT DRAIN

COOLING SYSTEM

Refilling the Coolant

After replacing the engine block drain plug, close the heat exchanger's coolant petcock. Then pour clean, premixed coolant and when the coolant is visible in the manifold, start the engine.

NOTE: When present, open the air-bleed petcock on the heat exchanger. When a steady flow of coolant appears at the petcock, close it and continue to fill the cooling system.

Monitor the coolant in the manifold and add as needed. Fill the manifold to the filler neck and install the manifold pressure cap.

Remove the cap on the coolant recovery tank and fill with coolant mix to halfway between LOW and MAX and replace the cap. Run the engine and observe the coolant expansion flow into the recovery tank.

After checking for leaks, stop the engine and allow it to cool. Coolant should draw back into the cooling system as the engine cools down. Add coolant to the recovery tank if needed. Clean up any spilled coolant.

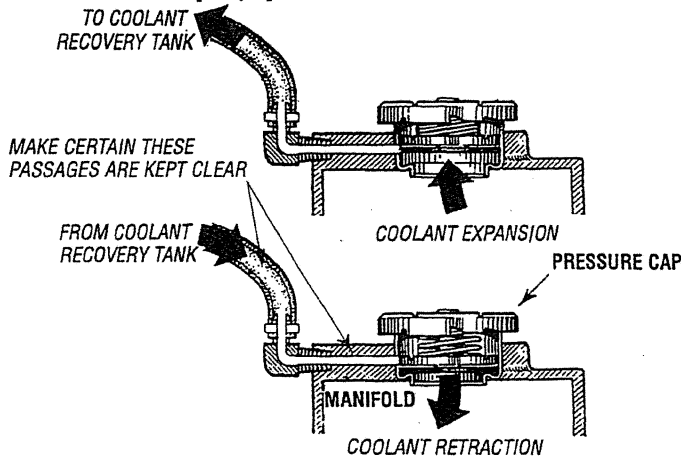

NOTE: Periodically check the condition of the manifold pressure cap. Ensure that the upper and lower rubber seals are in good condition and check that the vacuum valve opens and closes tightly. Carry a spare cap.



THERMOSTAT

A thermostat, located near the manifold at the front of the engine, controls the coolant temperature as the coolant continuously flows through the closed cooling circuit. When the engine is first started, the closed thermostat prevents coolant from flowing (some coolant is by-passed through a hole in the thermostat to prevent the exhaust manifold from overheating). As the engine warms up, the thermostat gradually opens. The thermostat is accessible and can be checked, cleaned, or replaced easily. Carry a spare thermostat and gasket.

Replacing the Thermostat

Remove the cap screws and disassemble the thermostat housing as shown. When installing the new thermostat and gasket, apply a thin coat of sealant on both sides of the gasket before pressing it into place. Do not over-tighten the cap screws.

Run the engine and check for normal temperatures and that there are no leaks at the thermostat housing.

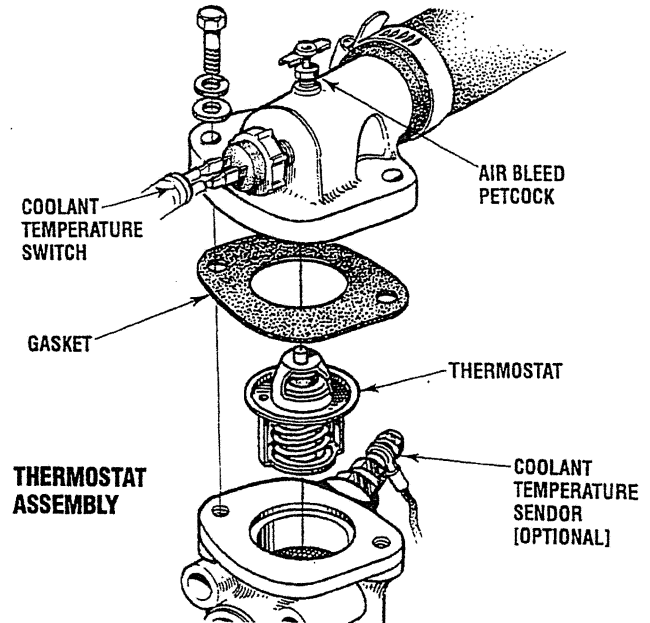

RAW WATER COOLING CIRCUIT

The raw water flow is created by a positive displacement impeller pump. This pump draws water directly from the raw water source (ocean, lake, or river) through a hose to the water strainer. The raw water passes from the strainer through the raw water pump to the heat exchanger (through the heat exchanger tubes) where it cools the engine circulating fresh water coolant. The raw water is then discharged into the water-injected exhaust elbow, mixing with and cooling the exhaust gasses. This mixture of exhaust gas and raw water is discharged overboard by the engine's exhaust gas discharge pressure.

Raw Water Pump

The raw water pump is a self-priming, rotary pump with a non-ferrous housing and a neoprene impeller. The impeller has flexible vanes which wipe against a curved cam plate within the impeller housing, producing the pumping action. On no account should this pump be run dry as water acts as a lubricant for the impeller. There should always be a spare impeller and impeller cover gasket (an impeller kit) aboard. Raw water pump impeller failures occur when lubricant (raw water) is not present during engine operation. Such failures are not warrantable, and operators are cautioned to make sure raw water flow is present at start-up.

NOTE: Should a failure occur with the pump's internal parts (seals and bearings), it may be more cost efficient to purchase a new pump and rebuild the original pump as a spare.

COOLING SYSTEM

CHANGING THE RAW WATER PUMP IMPELLER

Close the raw water intake valve. Remove the pump cover and gasket or O-ring with the aid of two screwdrivers or pliers. Carefully pry/pull the impeller out of the pump. Lightly coat the inside of the pump housing with *glycerine*. Install the new impeller, bending the blades in the direction of the curve of the cam plate. Re-assemble the gasket and cover. Open the raw water intake valve.

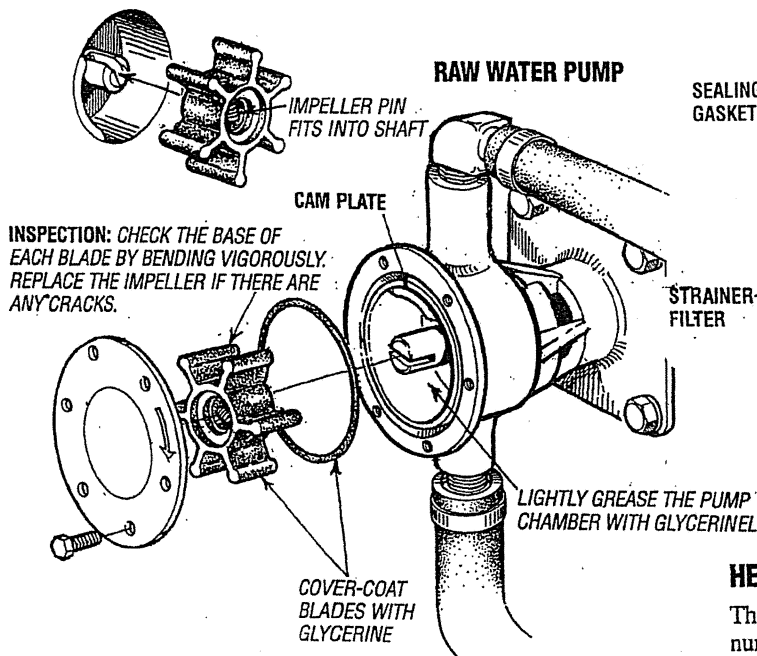

CAUTION: If any of the vanes have broken off the impeller, they must be found to prevent blockage in the cooling circuit. They often can be found in the heat exchanger.

Raw Water Intake Strainer

NOTE: Always install the strainer at or below the waterline so the strainer will always be self-priming.

A clean raw water intake strainer is a vital component of the engine's cooling system. Include a visual inspection of this strainer when making your periodic engine check. The water in the glass should be clear.

Perform the following maintenance after every 100 hours of operation:

1. Close the raw water seacock.
2. Remove and clean the strainer filter.
3. Clean the glass.
4. Replace the washer if necessary.
5. Reassemble and install the strainer.
6. Open the seacock.
7. Run the engine and check for leaks.

NOTE: Also follow the above procedure after having run hard aground.

If the engine temperature gauge ever shows a higher than normal reading, the cause may be that silt, leaves or grass may have been caught up in the strainer, slowing the flow of raw water through the cooling system.

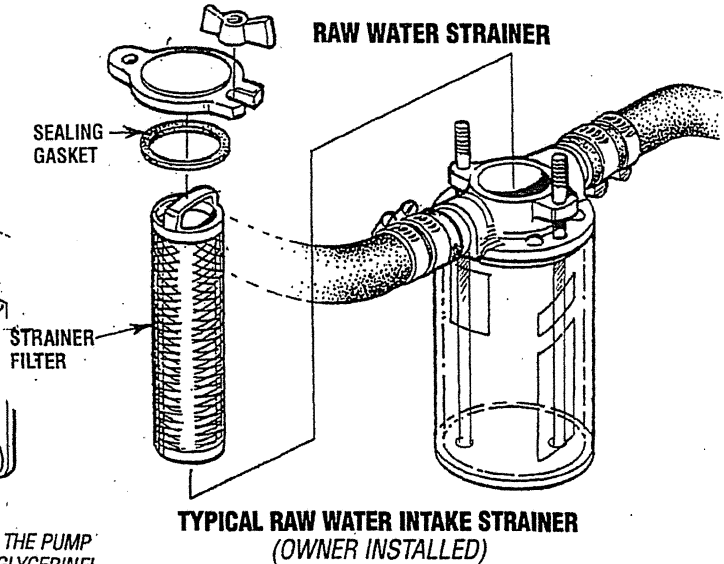

HEAT EXCHANGER

The heat exchanger is a copper cylinder which encloses a number of small copper tubes. Raw water is pumped through the small copper tubes and the fresh water coolant from the engine is circulated around the copper tubes. The raw water removes heat from the fresh water coolant.

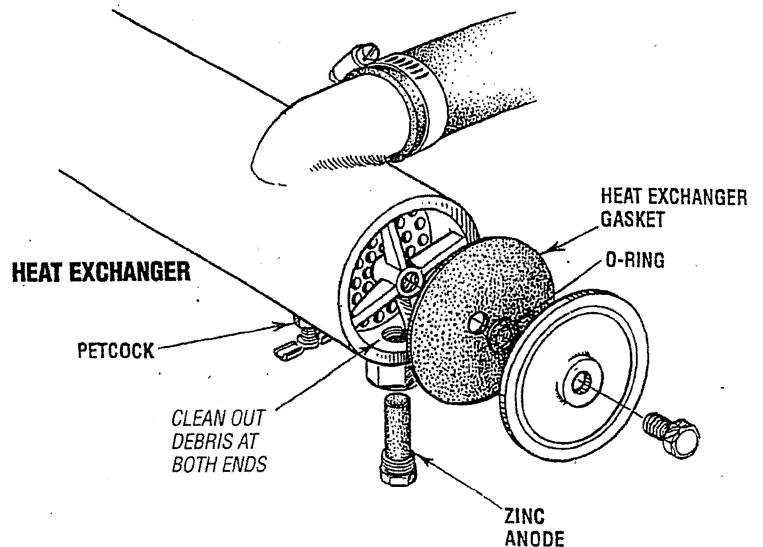

HEAT EXCHANGERS ARE ALSO AVAILABLE WITH CUPRO-NICKEL TUBING

COOLING SYSTEM

Zinc Anode

A zinc anode, or *pencil*, is located in the raw water cooling circuit within the heat exchanger. The purpose of having the zinc anode is to sacrifice itself to electrolysis action taking place in the raw water cooling circuit, thereby reducing the effects of electrolysis on other components of the system. The condition of the zinc should be checked monthly to determine its service life. Once that is established, the zinc replacement period can be noted in your maintenance log. Spare zinc anodes should be carried on board.

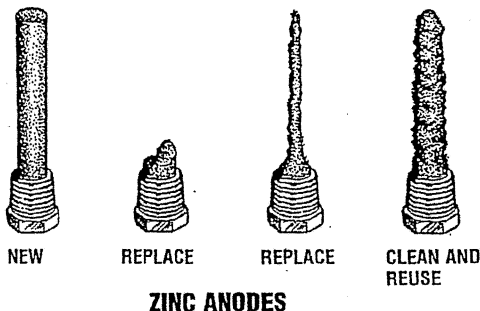

NOTE: Electrolysis action is the result of each particular installation and vessel location; not that of the engine.

If the zinc anodes need replacement, hold the hex boss into which the zinc anode is threaded with a wrench while loosening the anode with another wrench. This prevents the hex boss from possibly tearing off the exchanger shell. After removing the zinc, note the condition of it. If the zinc is in poor condition, there are probably a lot of zinc flakes within the exchanger. Remove the end of the heat exchanger and clean the inside of all zinc debris. Always have a spare heat exchanger end gasket in case the present one becomes damaged when removing the end cover. Replace the gasket (refer to your engine model's heat exchanger end gasket part number), O-ring and cover, and install a new zinc anode.

NOTE: The threads of the zinc anodes are pipe threads and do not require sealant. Sealant should not be used as it may insulate the zinc from the metal of the heat exchanger housing preventing electrolysis action on the zinc.

Heat Exchanger Service

After approximately 1000 hours of operation, remove, clean and pressure test the engine's heat exchanger. (A local automotive radiator shop should be able to clean and test the heat exchanger.)

NOTE: Operating in silty and/or tropical waters may require that a heat exchanger cleaning be performed more often than every 1000 hours.

AIR INTAKE / SILENCER

DESCRIPTION

A marine diesel engine running at 1800 rpm will typically consume as much as 6,000 cubic feet of air per hour. Not only must the engine room be well ventilated, the air flow into the engine must be unrestricted.

AIR INTAKE FILTER/SILENCER

The replaceable canister contains a paper element that should be inspected every 100 operating hours. Dirt in the element can be shaken off or cleaned with compressed air, however, if the element is greasy or black with dirt, the canister must be replaced, carry a spare.

NOTE: To operate efficiently a diesel engine must intake a continuous volume of clear air. Hard starting, an erratic idle, and black exhaust smoke are all symptoms of a restricted air intake.

FILTER CARTRIDGE INSTALLATION

Remove the two bolts that secure the air intake silencer housing to the base exposing the air filter element. Remove the filter element, inspect, clean and/or replace. Reinstall and secure the housing to the base with the two bolts.

NOTE: Regular inlet filter cartridge maintenance is essential for proper engine operation. Failure to maintain the inlet filter cartridge will result in air obstruction into the engine, causing poor fuel combustion and resulting in smokey/sooty exhaust discharge along with lube oil consumption and possible filter deterioration which could result in internal engine damage.

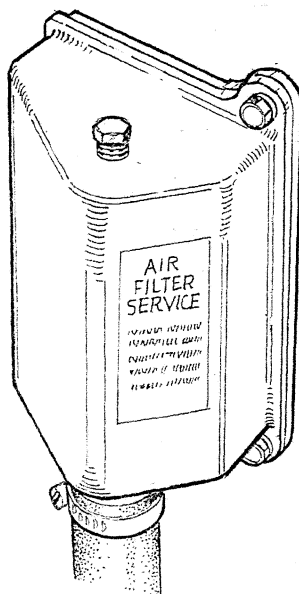

FILTER CARTRIDGE
PN#039705

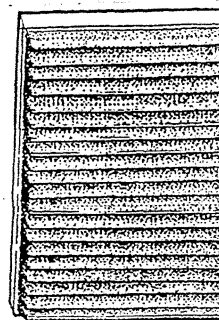

FUEL SYSTEM

DIESEL FUEL

Use a diesel fuel that meets the requirements of No. 2-D SAE J 313 and has a cetane rating of 45 or higher according to ASTM D975.

FUEL WATER SEPARATOR

A primary fuel filter of the water separating type must be installed between the fuel tank and the engine to remove water and other contaminant's from the fuel before they can be carried to the fuel system on the engine.

Most installers include a filter/water separator with the installation package as they are aware of the problems that contaminant's in the fuel can cause.

A typical fuel filter/water separator is illustrated below. This is the *Raycor Model 500 MA*. Keep in mind that if a water separator type filter is not installed between the fuel supply tank and engine-mounted fuel system, any water in the fuel will affect the fuel pump, engine filter, and injection equipment. The owner/operator is responsible for making certain the fuel reaching the engine's injection equipment is free of impurities. This process is accomplished by installing and maintaining a proper filtration/separation system.

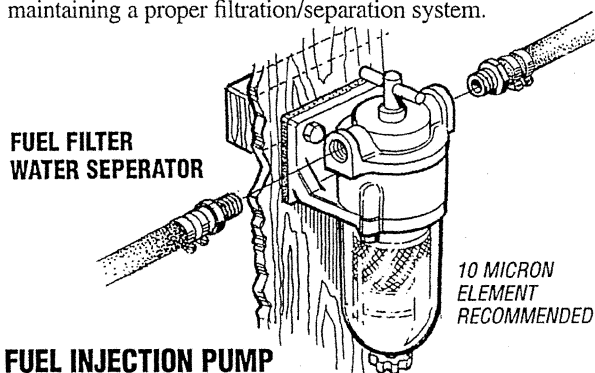

FUEL INJECTION PUMP

The fuel injection pump is the most important component of the diesel engine, requiring the utmost caution in handling. The fuel injection pump has been thoroughly bench-tested and the owner-operator is cautioned not to attempt to service it. If it requires servicing, remove it and take it to an authorized fuel injection pump service facility. Do not attempt to disassemble and repair it.

Speed (hertz) and timing are the only adjustments the servicing dealer can perform on the injection pump. Other types of adjustments or repairs must be performed by a qualified injection service shop.

FUEL LIFT PUMP

Periodically check the fuel connections to and out of the pump and make sure that no leakage is present and that the fittings are tight and secure. The DC ground connection at one of the pumps mounting bolts should be clean and well secured by the mounting bolt to ensure proper pump operations.

When energized thru the preheat circuit, the fuel lift pump will purge air from the fuel system and provide continuous flow of fuel as the engine is running.

FUEL FILTERS

The fuel injection pump and the fuel injectors are precisely manufactured and they must receive clean diesel fuel, free from water and dirt. To ensure this flow of clean fuel, the fuel must pass through at least two fuel filters, a fuel filter/water separator and the engine's spin-on fuel filter. Visually inspect, clean, and change these filters according to the maintenance schedule in this manual.

INLET FUEL FILTER

To ensure properly filtered fuel into the fuel pump, there is a small inlet filter before the inlet to the fuel pump. Replace this filter after the initial 50 hours of operation, then follow the Maintenance Schedule in this manual.

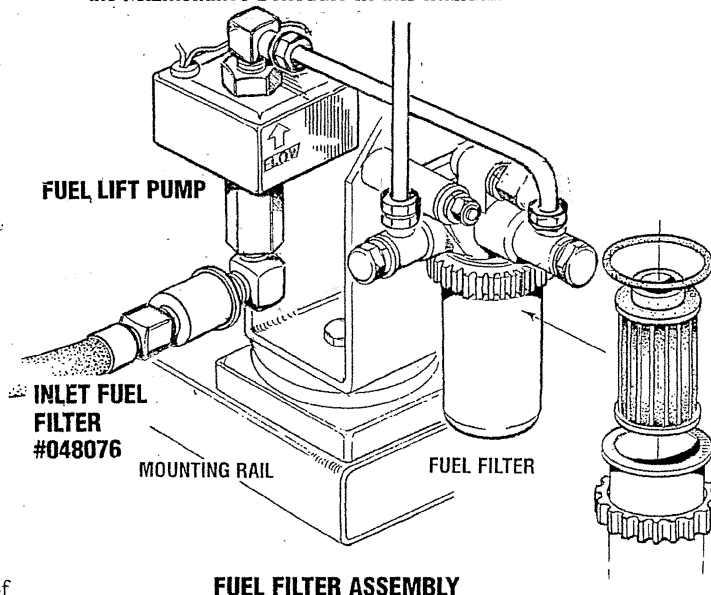

ENGINE FUEL FILTER

Periodically check the fuel connections and the bowl for leakage. Clean the filter element with kerosene or diesel fuel after the first 50 hours then follow the *MAINTENANCE SCHEDULE* for cleaning and replacement.

Changing/cleaning the filter element

1. Shut off the fuel supply.
2. Unscrew the retainer ring that holds the filter bowl to the housing and allow the bowl to come away from the housing,
3. Remove and replace the filter element and clean the bowl.
4. Replace the sealing "O" ring and reassemble the bowl to the housing. Thread the retainer ring on carefully so as not to cross thread. When retainer contacts the "O" ring, tighten 1/4 - 1/2 turns by hand. Open the fuel supply and run the engine to inspect for leaks.

ENGINE LUBRICATING OIL

LUBRICATION DIAGRAM

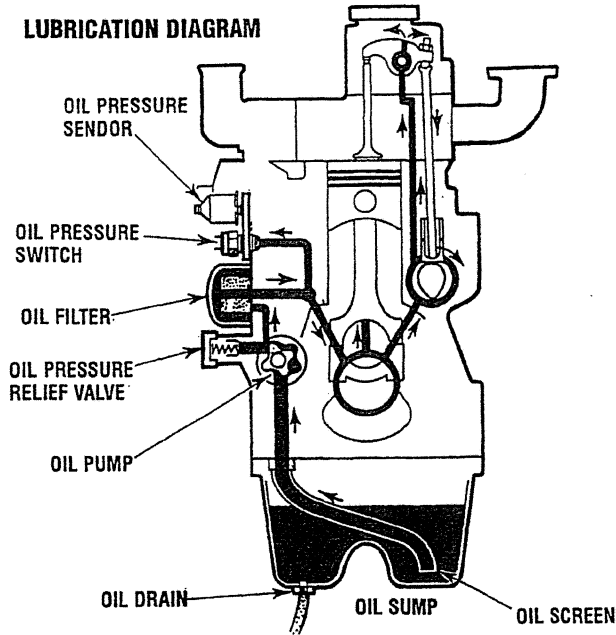

ENGINE OIL CHANGE

1. **Draining the Oil Sump.** Discharge the used oil through the sump drain hose (attached to the front of the engine) while the engine is warm. Drain the used oil completely, replace the hose in its bracket, and replace the end cap securely.

NOTE: Thread size for the lube oil drain hose capped end is 1/4" NPT.

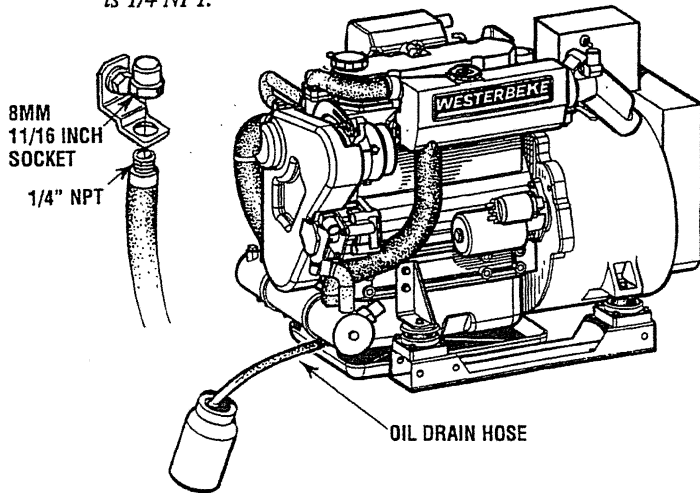

Always observe the used oil as it is removed. A yellow/gray emulsion indicates the presence of water in the oil. Although this condition is rare, it does require prompt attention to prevent serious damage. Call a qualified mechanic should water be present in the oil. Raw water present in the oil can be the result of a fault in the exhaust system attached to the engine and/or a siphoning of raw water through the raw water cooling circuit into the exhaust, filling the engine. This problem is often caused by the absence of an anti-siphon valve, its poor location or lack of maintenance.

2. **Replacing the Oil Filter.** When removing the used oil filter, you may find it helpful and cleaner to punch a hole in the upper and lower portion of the old filter to drain the oil from it into a container before removing it. This helps to lessen spillage. A small automotive filter wrench should be helpful in removing the old oil filter.

NOTE: Do not punch this hole without first loosening the filter to make certain it can be removed.

Place some paper towels and a plastic bag around the filter when unscrewing it to catch any oil left in the filter. (Oil or any other fluid on the engine reduces the engine's cooling ability. Keep your engine clean.) Inspect the old oil filter as it is removed to make sure that the rubber sealing gasket comes off with the old oil filter. If this rubber sealing gasket remains sealed against the filter bracket, gently remove it.

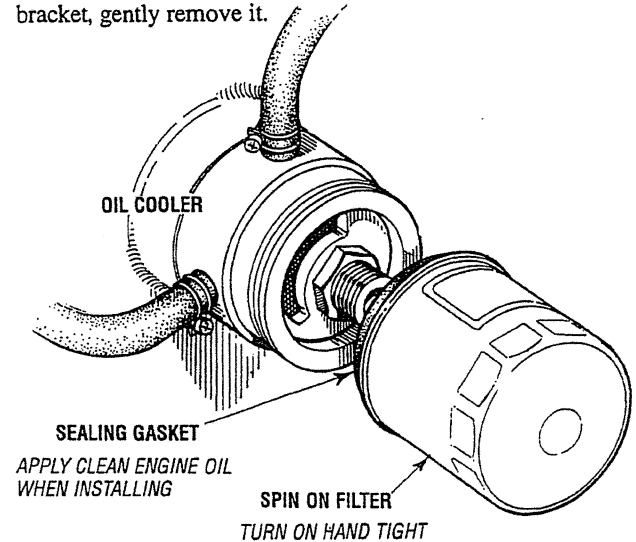

When installing the new oil filter element, wipe the filter gasket's sealing surface on the bracket free of oil and apply a thin coat of clean engine oil to the rubber gasket on the new oil filter. Screw the filter onto the threaded oil filter nipple on the oil filter bracket, and then tighten the filter firmly by hand.

NOTE: Generic filters are not recommended, as the material standards or diameters of important items on generic parts might be entirely different from genuine parts. Immediately after an oil filter change and oil fill, run the engine to make sure the oil pressure is normal and that there are no oil leaks around the new oil filter.

3. **Filling the Oil Sump.** Add new oil through the oil filler cap on the top of the engine or through the side oil fill. After refilling, run the engine for a few moments while checking the oil pressure. Make sure there is no leakage around the new oil filter or from the oil drain system, and stop the engine. Then check the quantity of oil with the lube oil dipstick. Fill to, but not over the high mark on the dipstick, should the engine require additional oil.

OIL PRESSURE

DESCRIPTION

The lubricating system is a pressure feeding system using an oil pump. The engine oil is drawn from the oil sump by the oil pump, which drives the oil, under pressure, through the oil filter, oil cooler and various lubricating points in the engine. The oil then returns to the oil sump to repeat the continuous cycle. When the oil pressure exceeds the specified pressure, the oil pushes open the relief valve in the oil pump and returns to the oil sump, keeping the oil pressure within its specified range.

OIL PRESSURE

The engine's oil pressure, during operation, is indicated by the oil pressure gauge on the instrument panel. During normal operation, the oil pressure will range between 40 and 60 psi (2.8 and 4.2 kg/cm²).

NOTE: A newly started, cold engine can have an oil pressure reading up to 60 psi (4.2 kg/cm²). A warmed engine can have an oil pressure reading as low as 35 psi (2.5 kg/cm²). These readings will vary depending upon the temperature of the engine and the rpms.

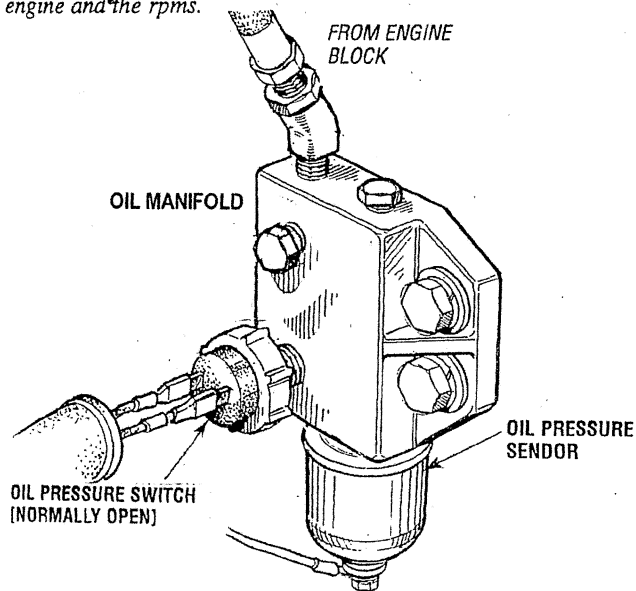

TESTING OIL PRESSURE

To test the oil pressure, remove the oil pressure sender, then install a mechanical oil pressure gauge in its place. After warming up the engine, set the engine speed at 1800 rpm and read the oil pressure gauge.

Oil Pressure 35.0 lb/in² (3.8 kg/cm²) or more at 1800 rpm.
Sender and Switch Torque 9 - 13 ft-lb (1.2 - 1.8 m - kg).

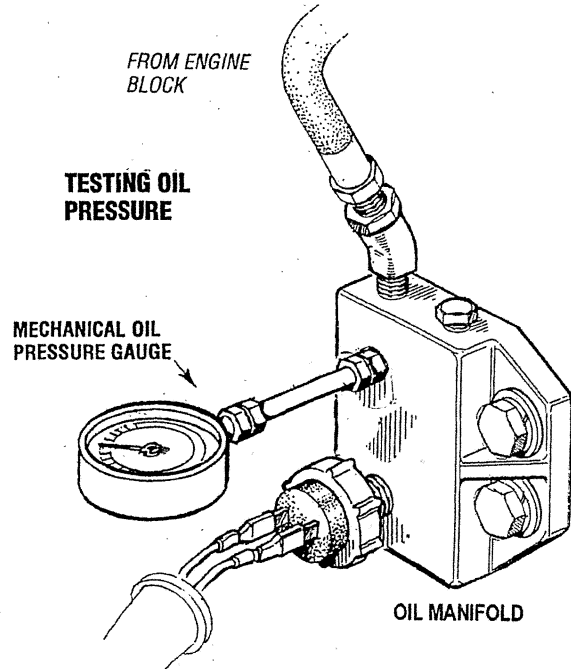

LOW OIL PRESSURE

The specified safe minimum oil pressure is 4.3 + 1.4 psi (0.3 + 0.1 kg/cm²). A gradual loss of oil pressure usually indicates a worn bearings. For additional information on low oil pressure readings, see the *ENGINE TROUBLESHOOTING* chart.

OIL PRESSURE RELIEF VALVE

An oil pressure relief valve is located on the engine block just below the injection pump. This valve opens at approximately 50 psi [343 kpa] and maintains that pressure.

LOCATED JUST UNDER THE FUEL INJECTION PUMP ON THE ENGINE BLOCK.

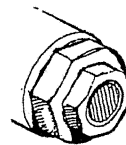

(OPTIONAL)
REMOTE OIL FILTER (OPTIONAL)
PN.040078

INSTALLATION

This popular accessory is used to relocate the engine's oil filter from the engine to a more convenient location such as an engine room bulkhead.

NOTE: Refer to *ENGINE OIL CHANGE* in this manual for instructions on removing the oil filter.

To install, simply remove the engine oil filter and thread on WESTERBEKE'S remote oil filter kit as shown. Always install this kit with the oil filter facing down as illustrated.

Contact your WESTERBEKE dealer for more information.

NOTE: Westerbeke is not responsible for engine failure due to incorrect installation of the Remote Oil Filter.

CAUTION: It is vital to install the oil lines correctly. If the oil flows in the reverse direction, the by-pass valve in the filter assembly will prevent the oil from reaching the engine causing an internal engine failure. If there is no oil pressure reading, shutdown immediately and check the hose connections

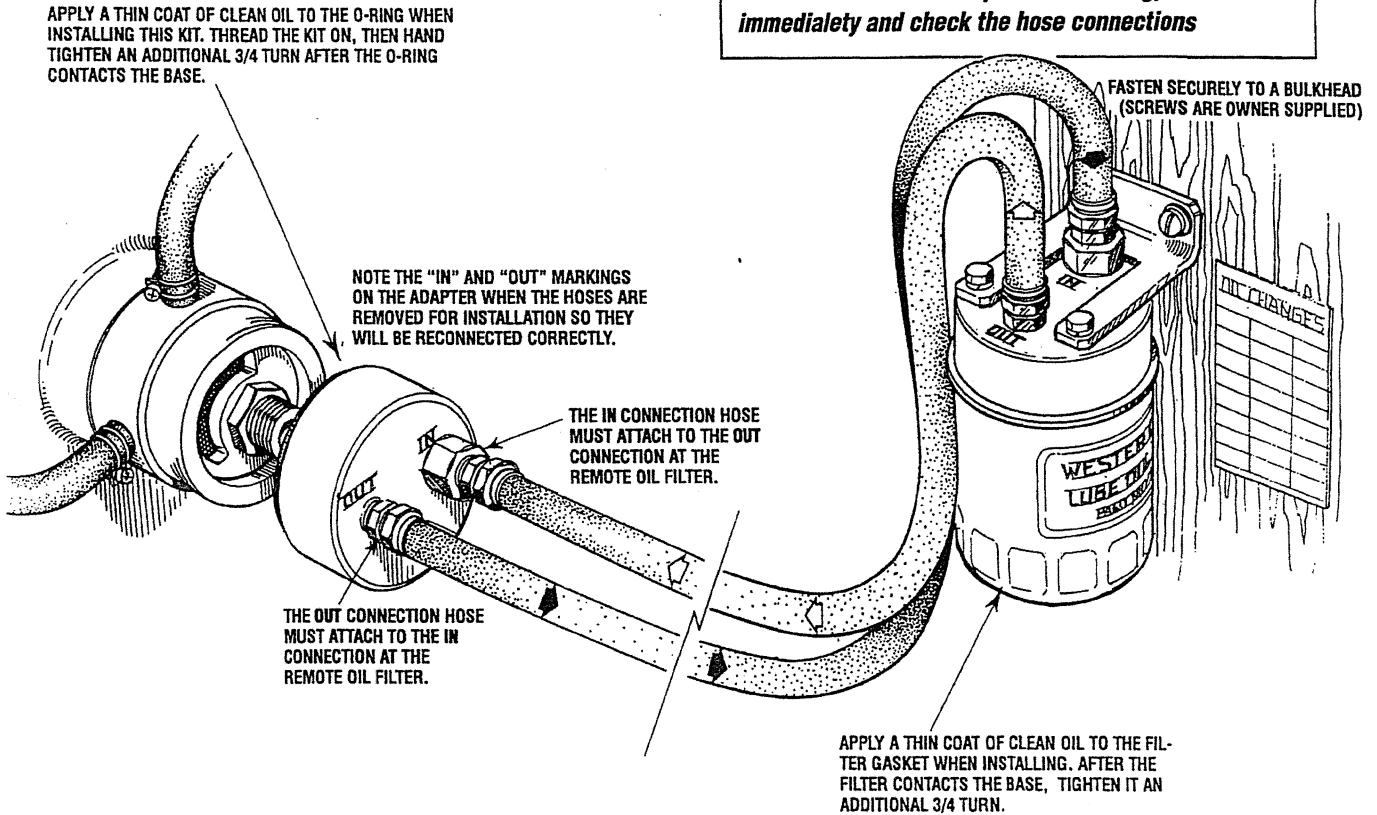

DC ELECTRICAL SYSTEM

ALTERNATOR

The charging system consists of a DC belt driven alternator with a voltage regulator, an engine DC wiring harness, a mounted DC circuit breaker and a battery with connecting cables. Because of the use of integrated circuits (IC's), the electronic voltage regulator is very compact and is mounted internally or on the back of the alternator.

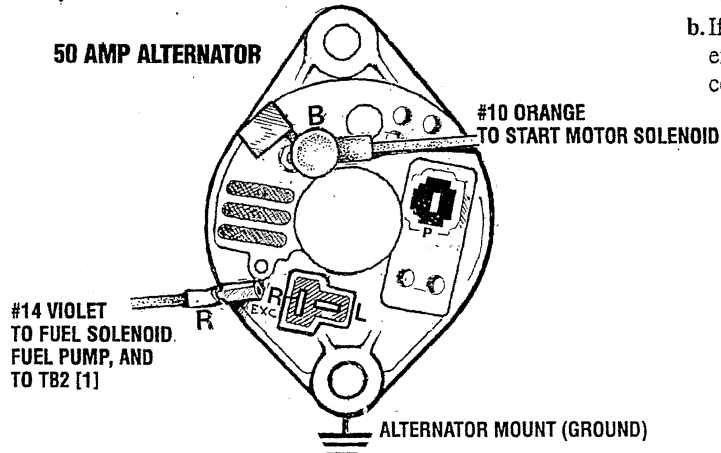

ALTERNATOR TROUBLESHOOTING

WARNING: A failed alternator can become very hot. Do not touch until the alternator has cooled down.

Use this troubleshooting section to determine if a problem exists with the charging circuit or with the alternator. If it is determined that the alternator or voltage regulator is faulty, have a qualified technician check it.

The alternator charging circuit charges the starting battery and the service battery. An isolator with a diode, a solenoid or a battery selector switch is usually mounted in the circuit to isolate the batteries so the starting battery is not discharged along with the service battery. If the alternator is charging the starting battery but not the service battery, the problem is in the service battery's charging circuit and not with the alternator.

Testing the Alternator

CAUTION: Before starting the engine make certain that everyone is clear of moving parts! Keep away from sheaves and belts during test procedures.

WARNING: When testing with a multimeter: DC and AC circuits are often mixed together in marine applications. Always disconnect a shore power cord, isolate DC and AC converters, and shut down the engine before performing DC testing. No AC tests should be made without a proper knowledge of AC circuits.

1. Start the engine.
2. After the engine has run for a few minutes, measure the starting battery voltage at the battery terminals using a multimeter set on DC volts.
 - a. If the voltage is increasing toward 14 volts, the alternator is working; omit Steps 3 through 8 and go directly to "Checking the Service Battery" on the next page.
 - b. If the voltage remains around 12 volts, a problem exists with either the alternator or the charging circuit; continue with Steps 3 through 8.

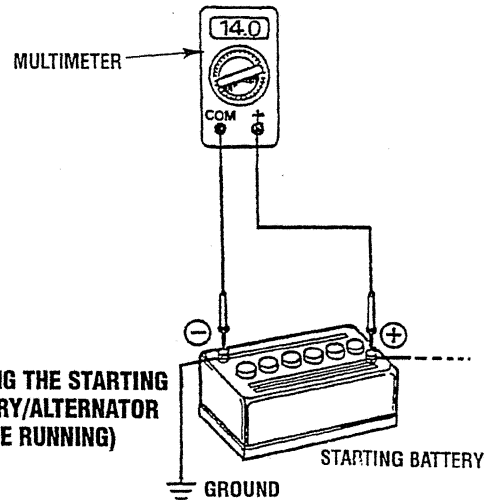

TESTING THE STARTING BATTERY/ALTERNATOR (ENGINE RUNNING)

3. Turn off the engine. Inspect all wiring and connections. Ensure that the battery terminals and the engine ground connections are tight and clean.

CAUTION: To avoid damage to the battery charging circuit, never shut off the engine battery switch when the engine is running!

4. If a battery selector switch is in the charging circuit, ensure that it is on the correct setting.
5. Turn on the ignition switch, but do not start the engine.
6. Check the battery voltage. If the battery is in good condition, the reading should be 12 to 13 volts.

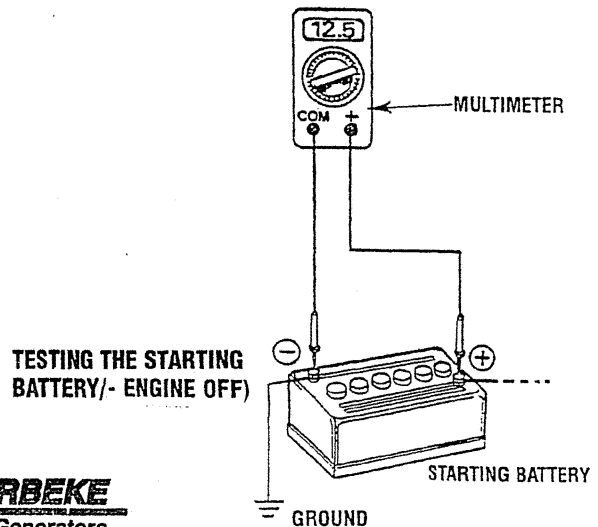

TESTING THE STARTING BATTERY/- ENGINE OFF)

DC ELECTRICAL SYSTEM

7. Now check the voltage between the alternator output terminal (B+) and ground. If the circuit is good, the voltage at the alternator will be the same as the battery, or if an isolator is in the circuit the alternator voltage will be zero. If neither of the above is true, a problem exists in the circuit between the alternator and the battery. Check all the connections — look for an opening in the charging circuit.

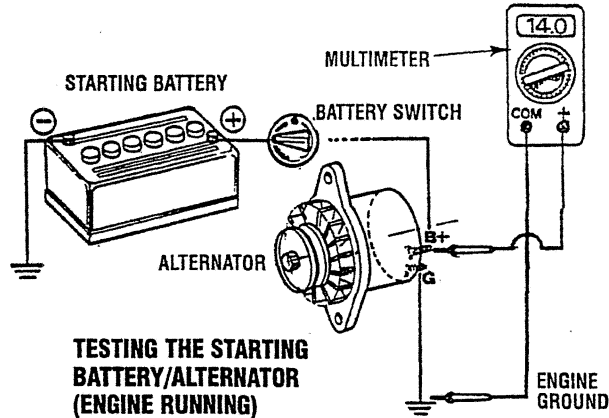

8. Start the engine again. Check the voltage between the alternator output and ground.
- The voltage reading for a properly operating alternator should be between 13.5 and 14.5 volts. If your alternator is over- or under-charging, have it repaired at a reliable service facility.

NOTE: Before removing the alternator for repair, use a voltmeter to ensure that 12 volts DC excitation is present at the EXC terminal if the previous test showed only battery voltage at the B output terminal.

If 12 volts is not present at the EXC terminal, trace the wiring and look for breaks and poor connections.

Checking the Service Battery

Check the voltage of the service battery. This battery should have a voltage between 13 and 14 volts when the engine is running. If not, there is a problem in the service battery charging circuit. Troubleshoot the service battery charging circuit by checking the wiring and connections, the solenoid, isolator, battery switch, and the battery itself.

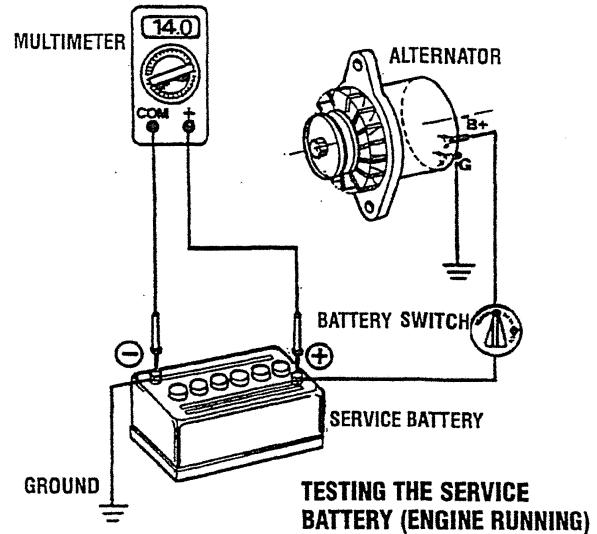

CAUTION: To avoid damaging the alternator diodes, do not use a high voltage tester (i.e. a megger) when performing tests on the alternator charging circuit.

12 VOLT DC CONTROL CIRCUIT

The engine has a 12 volt DC electrical control circuit that is shown on the wiring diagrams that follow. Refer to these diagrams when troubleshooting or when servicing the DC electrical system.

CAUTION: To avoid damage to the battery charging circuit, never shut off the engine battery switch while the engine is running. Shut off the engine battery switch, however, to avoid electrical shorts when working on the engine's electrical circuit.

BATTERY

The minimum recommended capacity of the battery used in the engine's 12 volt DC control circuit is 600 – 900 Cold Cranking Amps (CCA).

Battery Care

Review the manufacturer's recommendations and then establish a systematic maintenance schedule for your engine's starting batteries and house batteries.

- Monitor your voltmeter for proper charging during engine operation.
- Check the electrolyte level and specific gravity with a hydrometer.
- Use only distilled water to bring electrolytes to a proper level.
- Make certain that battery cable connections are clean and tight to the battery posts (and to your engine).
- Keep your batteries clean and free of corrosion.

WARNING: Sulfuric acid in lead batteries can cause severe burns on skin and damage clothing. Wear protective gear.

STARTER MOTOR

DESCRIPTION

The starter is a new type, small, light-weight and is called a high-speed internal-reduction starter. The pinion shaft is separate from the motor shaft; the pinion slides only on the pinion shaft. A reduction gear is installed between the motor shaft and a pinion shaft. The pinion sliding part is not exposed outside the starter so that the pinion may slide smoothly without becoming fouled with dust and grease. The motor shaft is supported at both ends on ball bearings. The lever mechanism, switch and overrunning clutch inner circuit are identical to conventional ones.

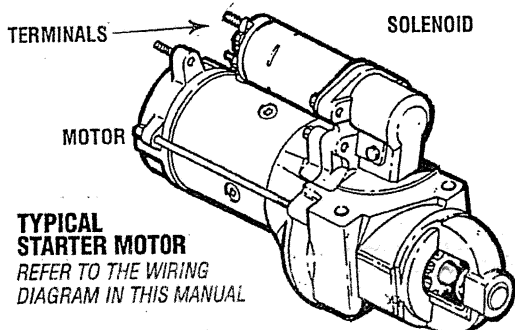

STARTER MOTOR

These are basically DC electric motors and used almost exclusively on small and large marine diesel propulsion engines and generators. These are direct current or compound wound starter motors. They operate either on 12 or 24 volts DC. On larger horsepower diesels, the starting motors are provided with reduction gears to transmit higher torque to crank the engine. You will also find reduction gear starter motors used on many smaller horsepower diesels to help provide good engine cranking speeds.

TROUBLESHOOTING

Prior to testing, make certain the ships batteries are at full charge and that the starting system wiring connections (terminals) are clean and tight. Pay particular attention to the ground wire connections on the engine block.

To check the wiring, try cranking the starter for a few seconds, never more than 10 seconds at a time, then run your hand along the wires and terminals looking for warm spots that indicate resistance. Repair or replace any trouble spots.

Using a multimeter, test the voltage between the positive terminal stud on the start solenoid and the engine block (ground).

If you read 12 volts, the starter is faulty.

⚠ WARNING: *The following emergency starting procedures **must not** be used with gasoline engines. Sparks could cause an explosion and fire.*

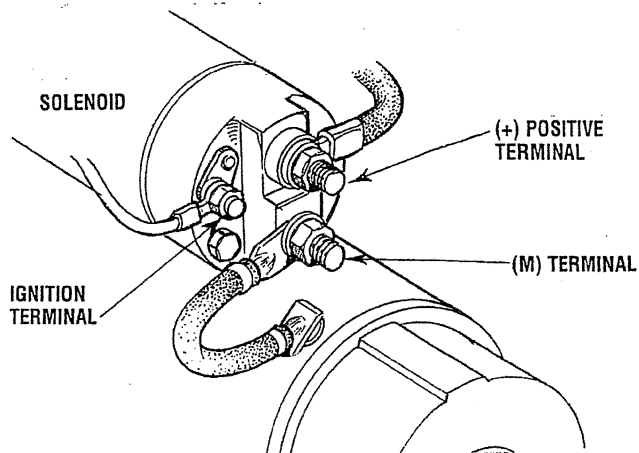

To test the ignition circuit, locate the ignition(s) terminal (it is one of the small terminal studs and is wired to the ignition circuit). Use a screwdriver, don't touch the blade, to jump from that ignition terminal to the positive battery connection terminal on the solenoid.

If the starter cranks, the fault lies with the ignition circuit.

If the solenoid clicks but nothing happens, the starter motor is probably faulty.

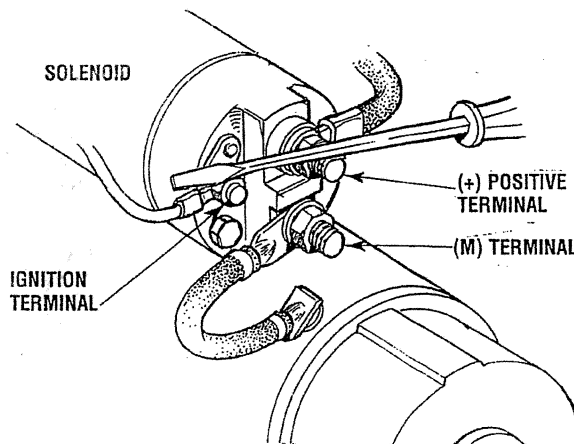

If nothing happens at all, the solenoid is not getting current. Check the battery isolation switch and inspect the wiring connections. It is also possible that the solenoid is defective.

⚠ WARNING: *There will be arcing and sparks will fly when jumping terminals. Be certain the engine space is free of potentially explosive fumes, especially gasoline, and that there are **NO** flammable solvents or materials stored nearby.*

STARTER MOTOR

⚠ WARNING: *When performing these procedures, position yourself safely away from the moving parts of the engine in case the engine starts-up. Also warn other crew members of the danger.*

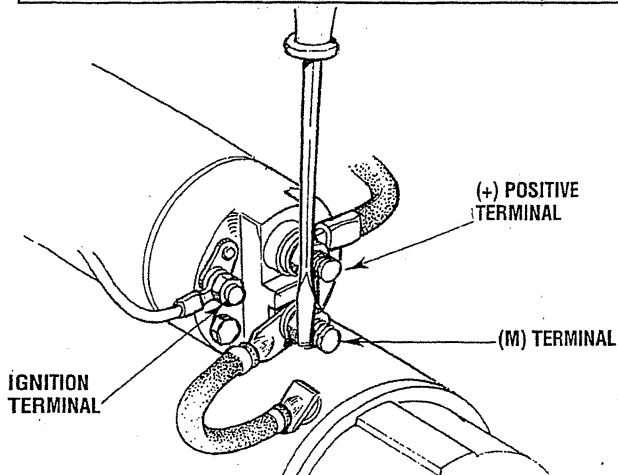

Test again by jumping the two large terminal studs. Hold the screwdriver blade firmly between the studs. Do not allow the screwdriver blade to touch the solenoid or starter casing, this would cause a short.

⚠ WARNING: *There will be arcing as the full starting current should be flowing thru the blade of the screwdriver.*

If the starter spins, the solenoid is faulty.

If the starter fails to spin, the motor is probably faulty.

If no arcing occurred, there is no juice reaching the solenoid.

SERVICE

Corrosion to the starter brushes and/or the solenoid contacts can cause the sporadic problem of the engine starting one time but not another. If corrosion is the problem, the starter will need to be rebuilt.

WESTERBEKE uses a standard starter motor which can be serviced or rebuilt at any starter motor automotive service center,

If replacing the starter motor, make certain the new motor is certified for marine use. Automotive starters do not meet USCG standards. If in doubt, contact your WESTERBEKE dealer.

TO REMOVE FOR SERVICE

1. Disconnect the negative battery cable.
2. If necessary, remove any components to gain full access to the starter motor.
3. Label and disconnect the wiring from the starter. (Do not allow wires to touch, tape over the terminals).
4. Remove the starter mounting bolts.
5. Remove the starter from the engine. In some cases the starter will have to be turned to a different angle to clear obstructions,

ENGINE TROUBLESHOOTING

ENGINE SHUTDOWN/CHECK ENGINE LIGHT

ELECTRONIC CONTROLLER

The Electronic Control Unit (ECU) monitors and controls all aspects of the drive engines operation. The unit is factory programmed and the programming can not be altered. The ECU is mounted on the engine block adjacent to the fuel injection pump and controls the injection pumps operation. If an operating fault occurs, the ECU will shutdown the engine and illuminate the **Check Engine LED**. When the operating fault has been investigated and corrected, the ECU must be re-set to re-start the engine. To re-set the ECU, turn the DC breaker on the control panel OFF, then ON.

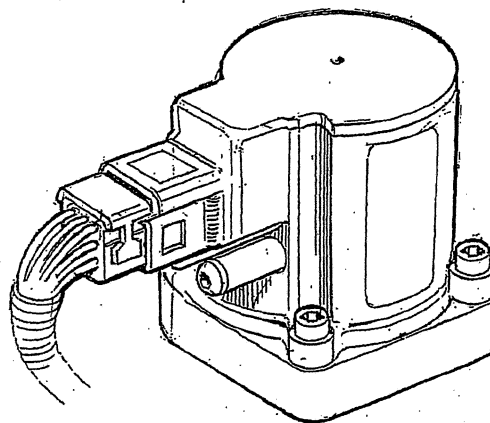

ENGINE SHUTDOWN CHECK ENGINE/LED IS ILLUMINATED

PROBLEM	PROBABLE CAUSE	VERIFICATION/REMEDY
LOW OIL PRESSURE	<ol style="list-style-type: none"> 1. Oil level low/oil leak. 2. Lack of oil pressure. 3. AGround connection. 4. Faulty oil pressure switch. 	<ol style="list-style-type: none"> 1. Check oil level, add oil and repair leaks. 2. Test oil pressure. If OK, test oil pressure sensor, inspect oil filter, inspect oil pump. 3. Check ground connection. 4. Check sensor/replace.
HIGH COOLANT TEMPERATURE	<ol style="list-style-type: none"> 1. Check system coolant level. 2. Sea water pump. 3. Check water pump drive belt. 4. Faulty temperature switch. 5. Ground connection. 	<ol style="list-style-type: none"> 1. Add coolant. Check for leaks. 2. Inspect impeller/pump/replace. 3. Adjust belt tension, replace belt. 4. Check sensor/replace. 5. Check ground circuit.
BATTERY VOLTAGE (HIGH DC/LOW DC)	<ol style="list-style-type: none"> 1. Check alternator drive belt.. 2. Check charge voltage. 3. Check battery connections. 4. faulty battery. 	<ol style="list-style-type: none"> 1. Adjust tension/replace if worn. 2. Check excitation. Replace/repair alternator. 3. Check + and - cables from battery to engine. 4. Load test battery.
GENERATOR FREQUENCY Overspeed Underspeed	<ol style="list-style-type: none"> 1. Check engine speed. 2. Check fuel supply. 3. Amperage load. 4. Crank cycle with no start. (underspeed fault) 5. Generator Shut-down. (underspeed fault) 	<ol style="list-style-type: none"> 1. Check speed setting. 2. Inspect filters/replace filters. Test fuel pump operation. 3. Check + and - cables from battery to engine. 4. Check cause for no start. 5. Check MPU (voltage cranking. (Check MPU - coil resistance)
HIGH EXHAUST (External Fault)	<ol style="list-style-type: none"> 1. Check sea water flow. 2. Faulty exhaust temperature switch. 3. Ground connection. 4. Sea water pump. 5. Faulty fire suppression system. 	<ol style="list-style-type: none"> 1. Inspect thru hull fitting, hose and strainer. Correct as needed. 2. Test/replace. 3. Check ground circuit. 4. Inspect impeller/replace. 5. By-pass system/check.

Under no circumstances should the Electronic Controller be removed from the unit without consulting with the factory first.

ENGINE TROUBLESHOOTING

PROBLEM	PROBABLE CAUSE	VERIFICATION/REMEDY
Generator engine cranks but does not start.	<ol style="list-style-type: none"> 1. Faulty preheat circuit. 2. Faulty fuel pump. 3. Fuel supply. 4. Fuel filter(s) contaminated. 	<ol style="list-style-type: none"> 1. Test/check circuit components. 2. Test fuel pump operation. 3. Check fuel ON. 4. Inspect all filters.
Starting battery looses charge.	<ol style="list-style-type: none"> 1. Faulty battery. 2. Oil pressure switch stuck, closed contacts. 3. DC alternator faults. 	<ol style="list-style-type: none"> 1. Load test battery. 2. Panel/fuel pump activated after shutdown. 3. Check alternator charge rate.
Engine shuts down. Low oil pressure.	<ol style="list-style-type: none"> 1. Loss of oil. 2. Oil pressure switch. 3. Contaminated oil. 	<ol style="list-style-type: none"> 1. Locate leak and correct. 2. Test/replace. 3. Change oil, locate source of contaminates.
Smokey exhaust.	<ol style="list-style-type: none"> 1. Blue smoke. 2. White smoke. 3. Black smoke. 	<ol style="list-style-type: none"> 1. Crankcase overfilled. 2. Incorrect grade of oil. 1. Engine running cold, thermostat stuck open. 2. Faulty injector. 1. Lack of air, check intake/air filter. 2. Incorrect fuel grade. 3. Valves need adjustment. 4. Low compression.
Engine starts, runs then shutdown. (stays running with Preheat depressed).	<ol style="list-style-type: none"> 1. Safety shutdown switch faulty. 	<ol style="list-style-type: none"> 1. Check safety shutdown switch (oil, coolant, exhaust)
Engine has loss of horsepower.	<ol style="list-style-type: none"> 1. MAP sensor (manifold absolute pressure). 	<ol style="list-style-type: none"> 1. Test/replace.

ENGINE TROUBLESHOOTING

The following troubleshooting chart describes certain problems relating to engine service, the probable causes of these problems, and the recommendations to overcome these problems. If the engine shuts down (**Check Engine/LED is illuminated**), refer to ECU Troubleshooting Chart in this manual.

NOTE: The engine's electrical system is protected by a 20-ampere manual reset circuit breaker. The preheat solenoid is mounted on the same bracket.

PROBLEM	PROBABLE CAUSE	VERIFICATION/REMEDY
Engine can not be stopped.	1. Faulty DC alternator.	1. Remove Exc/R connection off alternator. Repair alternator.
Starting battery not being.	1. DC charge circuit faulty. 2. Alternator drive.	1. Perform DC voltage check of charge circuit. See DC alternator section in this manual. 2. Check drive belt tension, loose connections, voltage output, excitation voltage present at Exo/R terminal.
Engine slows and stops.	1. Fuel starvation. 2. Contaminated fuel. 3. Exhaust restriction.	1. Check fuel supply, filters, tank vent. 2. Check filters for contaminates/water. 3. Check for blockage, collapsed exhaust hose, carbon build up in water injected exhaust elbow.
Engine overheats and shuts down.	1. Antifreeze coolant not circulating.	1. Loss of coolant. Check system for leak. 2. Air in system. Expel air. Add coolant as needed. Check recovery circuit. 3. Thermostat stuck closed. Check/test/replace.
Preheat switch depressed No panel indications or electrical fuel pump.	1. Battery switch off. 2. 20 Amp breaker tripped. 3. Emergency stop switch open. 4. 7.5 amp fuse faulty. 5. Blocking diode open. 6. K2 Relay faulty.	1. Check switch. 2. Check/re-set 20 amp breaker. 3. Check/close switch. 4. Check/test fuse. 5. Test diode. 6. Check/test K2 Relay.
Start switch depressed No starter activation.	1. K1 Relay faulty. 2. Faulty starter solenoid. 3. Low DC battery charge. 4. Poor/loose battery cable connection.	1. Check/test K1 Relay. 2. Test solenoid. 3. Check battery charge state. 4. Check connections.

TROUBLESHOOTING WATER TEMPERATURE AND OIL PRESSURE GAUGES

If the gauge reading is other than what is normally indicated by the gauge when the instrument panel is energized, the first step is to check for 12 volts DC between the ignition (B+) and the Negative (B-) terminals of the gauge.

Assuming that there is 12 volts as required, leave the instrument panel energized and perform the following steps:

1. Disconnect the sender wire at the gauge and see if the gauge reads zero, which is the normal reading for this situation.
2. Remove the wire attached to the sender on the engine and ground it to the engine. The gauge in the panel should register full scale, which is normal for this situation. DC voltage at the oil and temperature sender to ground when the engine is first started will be high (10 - 11VDC) and will fall as the oil pressure rises and coolant rises. This DC voltage will generally stabilize in the 5 - 7VDC range depending on what your engines normal oil pressure and coolant temperature are.

If both of the above gauge tests are positive, the gauge is undoubtedly OK and the problem lies either with the conductor from the sender to the gauge or with the sender.

If either of the above gauge tests are negative, the gauge is probably defective and should be replaced.

Assuming the gauge is OK, check the conductor from the sender to the sender terminal at the gauge for continuity.

Check that the engine block is connected to the ground. Some starters have isolated ground terminals and if the battery is connected to the starter (both plus and minus terminals), the ground side will not necessarily be connected to the block.

ENGINE ADJUSTMENTS

NOTE: WESTERBEKE recommends that the following engine adjustments be performed by a competent engine mechanic. The information below is provided to assist the mechanic.

GLOW PLUGS TYPICAL

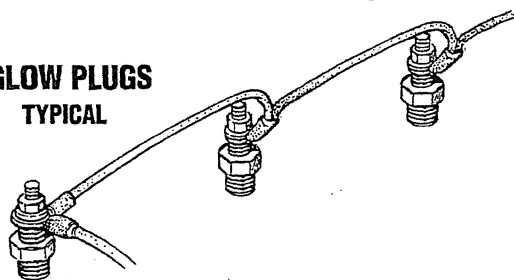

DESCRIPTION

The glow plugs are wired through the preheat solenoid. When PREHEAT is pressed at the control panel this solenoid should “click” on and the glow plug should begin to get hot.

INSPECTION

To inspect the plug, remove the electrical terminal connections, then unscrew or unclamp each plug from the cylinder head. Thoroughly clean each plug’s tip and threads with a soft brush and cleaning solution to remove all the carbon and oil deposits. While cleaning, examine the tip for wear and burn erosion; if it has eroded too much, replace the plug.

TESTING

An accurate way to test glow plugs is with an ohmmeter. Touch one prod to the glow plug’s wire connection, and the other to the body of the glow plug, as shown. A good glow plug will have a 1.0- to 1.5-ohm resistance. This method can be used with the plug in or out of the engine. You can also use an ammeter to test the power drain (8 to 9 amps per plug).

WARNING: These glow plugs will become very hot to the touch. Be careful not to burn your fingers when testing the plugs

Re-install the plugs in the engine and test them again. The plugs should get very hot (at the terminal end) within 20 to 25 seconds. If the plugs don’t heat up quickly, check for a short circuit. When reinstalling the glow plugs, use anti-seize compound on the threads.

Glow Plug Tightening Torque 7 - 11 lb-ft (1.0 - 1.5 kg-m)

WARNING: Do not keep a glow plug on for more than 30 seconds

FUEL INJECTORS

In case of severe vibrations and detonation noise, have the injectors checked and overhauled by an authorized fuel injection service center. Poor fuel quality, contaminants and loss of positive fuel pressure to the injection pump can result in injector faults. Since fuel injectors must be serviced in a clean room environment, it is best to carry at least one extra injector as a spare should a problem occur.

Before removing the old injector, clean the area around the base of the injector to help prevent any rust or debris from falling down into the injector hole. If the injector will not lift out easily and is held in by carbon build-up or the like, work the injector side-to-side with the aid of the socket wrench to free it, and then lift it out.

The injector seats in the cylinder head on a copper sealing washer. This washer should be removed with the injector and replaced with a new washer when the new injector is installed.

Injector to Cylinder Head Tightening Torque 40 ± 4 ft-lb (5.5 ± 0.5 kgf-m)

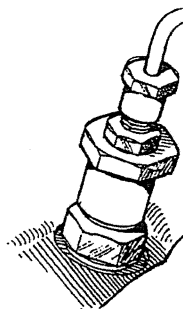

FUEL INJECTOR

REFER TO YOUR WESTERBEKE SERVICE MANUAL FOR TESTING AND SERVICING OF FUEL INJECTORS.

ENGINE ADJUSTMENTS

NOTE: WESTERBEKE recommends that the following engine adjustments be performed by a competent engine mechanic. The information below is provided to assist the mechanic.

VALVE CLEARANCE ADJUSTMENT

Make the following adjustments when the engine is cold.

1. Remove the cylinder head cover.
2. Prior to checking valve clearances, re-torque the cylinder head hold down bolts. This is done by slightly loosening the bolt and then re-tightening the bolt to the specified torque in the sequence shown below.

Tightening Torque 65 ± 4 lb-ft (88 ± 5 Nm)

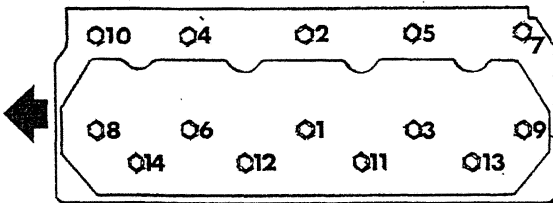

FOUR CYLINDER

FRONT

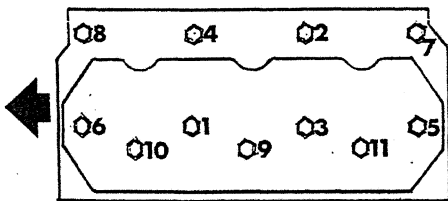

THREE CYLINDER

3. Find top dead center compression position for No.1 piston by using the procedure that follows:
 - (a) Remove the glow plugs from the engine to ease the rotation of the crankshaft manually to position the various cylinders pistons at TDC (Top Dead Center).

TDC (TOP DEAD CENTER)

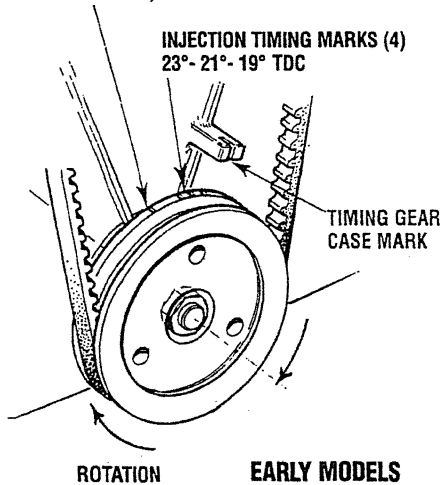

EARLY MODELS

- (b) Rotate the crankshaft to position #1 cylinder piston at TDC. The TDC mark on the crank pulley should align with the timing mark on the gear case. Adjust the valves for cylinder #1.
- (c) Rotate the crankshaft to position the next cylinder in the engines firing order at TDC of its compression stroke. Adjust the valves for that cylinder.
- (d) Rotate the crankshaft to position the next cylinder in the engines firing order at TDC. Adjust the cylinders valves and repeat this procedure until all the cylinder valves are adjusted.

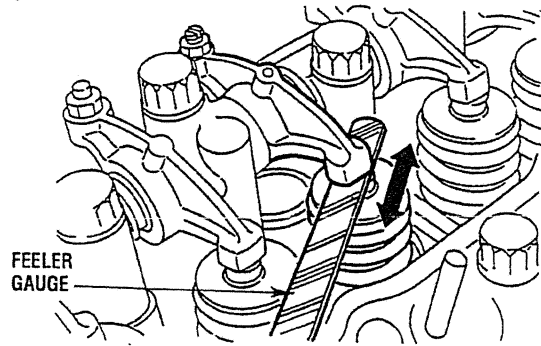

4. Loosen the lock nut for the adjusting screw. With a feeler gauge inserted between the rocker arm and valve cap, adjust the valve clearance by turning the adjusting screw. Make certain to adjust all the valves.

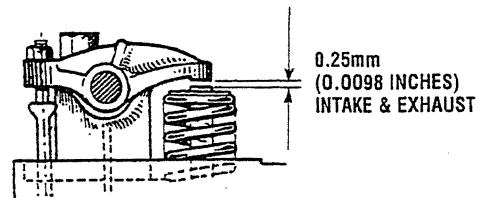

5. Install the cylinder head cover.
Head Cover Bolt Torque $2 - 3$ ft-lb ($0.3 - 0.45$ m-kg)

FIRING ORDER:
3 CYLINDER: 1-3-2
4 CYLINDER: 1-3-4-2

INJECTION TIMING MARKS (7)
21°- 20°- 19°- 18°- 17°- 16° TDC

TDC (TOP DEAD CENTER)

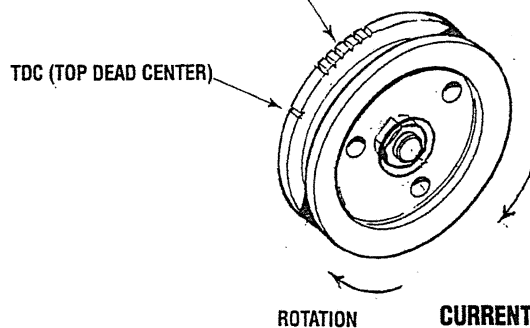

CURRENT MODELS

GENERATOR INFORMATION

USE OF ELECTRIC MOTORS

The power required to start an electric motor is considerably more than is required to keep it running after it is started. Some motors require much more current to start them than others. Split-phase (AC) motors require more current to start, under similar circumstances, than other types. They are commonly used on easy-starting loads, such as washing machines, or where loads are applied after the motor is started, such as small power tools. Because they require 5 to 7 times as much current to start as to run, their use should be avoided, whenever possible, if the electric motor is to be driven by a small generator. Capacitor and repulsion-induction motors require from 2 to 4 times as much current to start as to run. The current required to start any motor varies with the load connected to it. An electric motor connected to an air compressor, for example, will require more current than a motor to which no load is connected.

In general, the current required to start 115-Volt motors connected to medium starting loads will be approximately as follows:

MOTOR SIZE (HP)	AMPS FOR RUNNING (AMPERES)	AMPS FOR STARTING (AMPERES)
1/6	3.2	6.4 to 22.4*
1/4	4.6	9.2 to 32.2*
1/3	5.2	10.4 to 72.8*
1/2	7.2	14.4 to 29.2*
3/4	10.2	20.4 to 40.8*
1	13	26 to 52

***NOTE:** In the above table the maximum Amps for Starting is more for some small motors than for larger ones. The reason for this is that the hardest starting types (split-phase) are not made in larger sizes.

Because the heavy surge of current needed for starting motors is required for only an instant, the generator will not be damaged if it can bring the motor up to speed in a few seconds. If difficulty is experienced in starting motors, turn off all other electrical loads and, if possible, reduce the load on the electric motor.

REQUIRED OPERATING SPEED

Run the generator first with no load applied, then at half the generator's capacity, and finally loaded to its full capacity as indicated on the generator's data plate. The output voltage should be checked periodically to ensure proper operation of the generating plant and the appliances it supplies. If an AC voltmeter or ampmeter is not installed to monitor voltage and load, check it with a portable meter and amp probe.

NOTE: When the vessel in which the generator is installed contains AC equipment of 120 volts only, it is recommended that the generator's AC terminal block be configured to provide one 120 volt AC hot leg for the vessel's distribution panel. This will ensure good motor starting response from the generator.

GENERATOR FREQUENCY

The generators speed can not be changed in the field from the standard 60 hertz operation to 50 hertz operation. 50 hertz generators must be specifically ordered and for overseas operation only. This is because the drive engine is only certified to operate at 1800 rpm (60Hz) in the United States. Operating this drive engine at 1500 rpm (50Hz) in the United States may be in violation of Federal Law.

GENERATOR MAINTENANCE

- Maintaining reasonable cleanliness is important. Connections of terminal boards and rectifiers may become corroded, and insulation surfaces may start conducting if salts, dust, engine exhaust, carbon, etc. are allowed to build up. Clogged ventilation openings may cause excessive heating and reduced life of windings.
- For unusually severe conditions, thin rust-inhibiting petroleum-base coatings, should be sprayed or brushed over all surfaces to reduce rusting and corrosion.
- In addition to periodic cleaning, the generator should be inspected for tightness of all connections, evidence of overheated terminals and loose or damaged wires.
- The drive discs on single bearing generators should be checked periodically if possible for tightness of screws and for any evidence of incipient cracking failure. Discs should not be allowed to become rusty because rust may accelerate cracking. The bolts which fasten the drive disc to the generator shaft must be hardened steel SAE grade 8, identified by 6 radial marks, one at each of the 6 corners of the head.
- The rear armature bearing is lubricated and sealed; no maintenance is required. However, if the bearing becomes noisy or rough-sounding, have it replaced.
- Examine bearing at periodic intervals. No side movement of shaft should be detected when force is applied. If side motion is detectable, inspect the bearing and shaft for wear. Repair must be made quickly or major components will rub and cause major damage to generator.

Carbon Monoxide Detector

WESTERBEKE recommends mounting a carbon monoxide detector in the vessels living quarters. **Carbon monoxide, even in small amounts, is deadly.**

The presence of carbon monoxide indicates an exhaust leak from the engine or generator or from the exhaust elbow/exhaust hose, or that fumes from a nearby vessel are entering your boat.

If carbon monoxide is present, ventilate the area with clean air and correct the problem immediately!

BT GENERATOR

This generator is a four-pole, brushless, self-excited generator which requires only the driving force of the engine to produce AC output. The copper and laminated iron in the exciter stator are responsible for the self-exciting feature of this generator. The magnetic field produced causes an AC voltage to be induced into the related exciter rotor windings during rotation. Diodes located in the exciter rotor rectify this voltage to DC and supply it to the windings of the rotating field. This creates an electromagnetic field which rotates through the windings of the main stator, inducing an AC voltage which is supplied to a load. A step down transformer is connected in parallel to the AC output of the main stator. An AC voltage is produced in the auxiliary windings of the transformer and the main stator and is, in turn, supplied to a full-wave bridge rectifier. The rectifier produces a DC voltage to further excite the exciter stator windings, enabling the generator to produce a rated AC output. An optional solid-state voltage regulator is available to work in tandem with the transformer regulator to produce a more stable AC output.

A circuit breaker is installed on all WESTERBEKE generators. This circuit breaker will automatically disconnect generator power in case of an electrical overload. The circuit breaker can be manually shut off when servicing the generator to ensure no power is coming into the boat.

NOTE: This circuit breaker is available as a WESTERBEKE add-on kit for earlier model generations; contact your WESTERBEKE dealer.

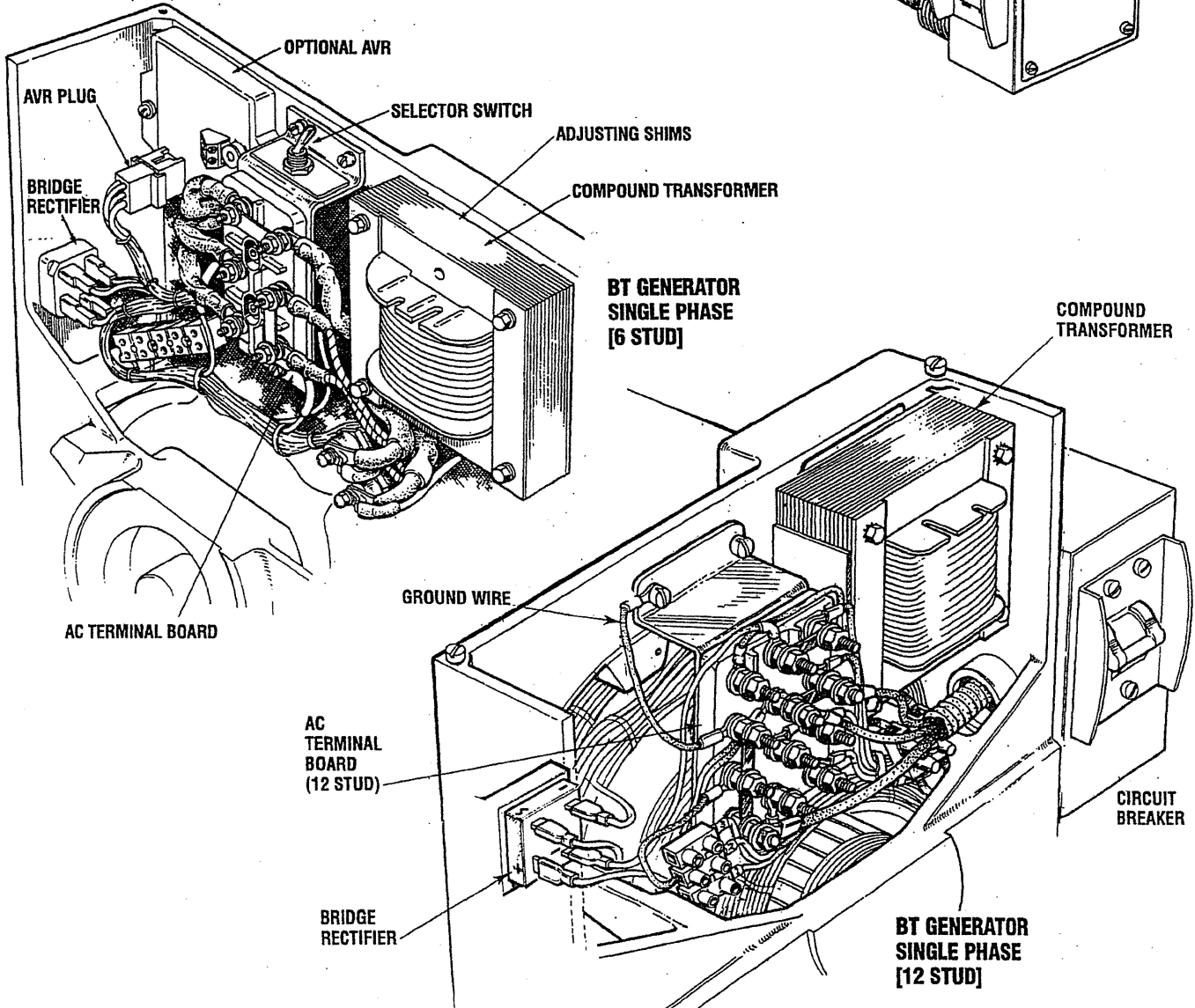

BT GENERATOR / SINGLE PHASE [SIX STUD]

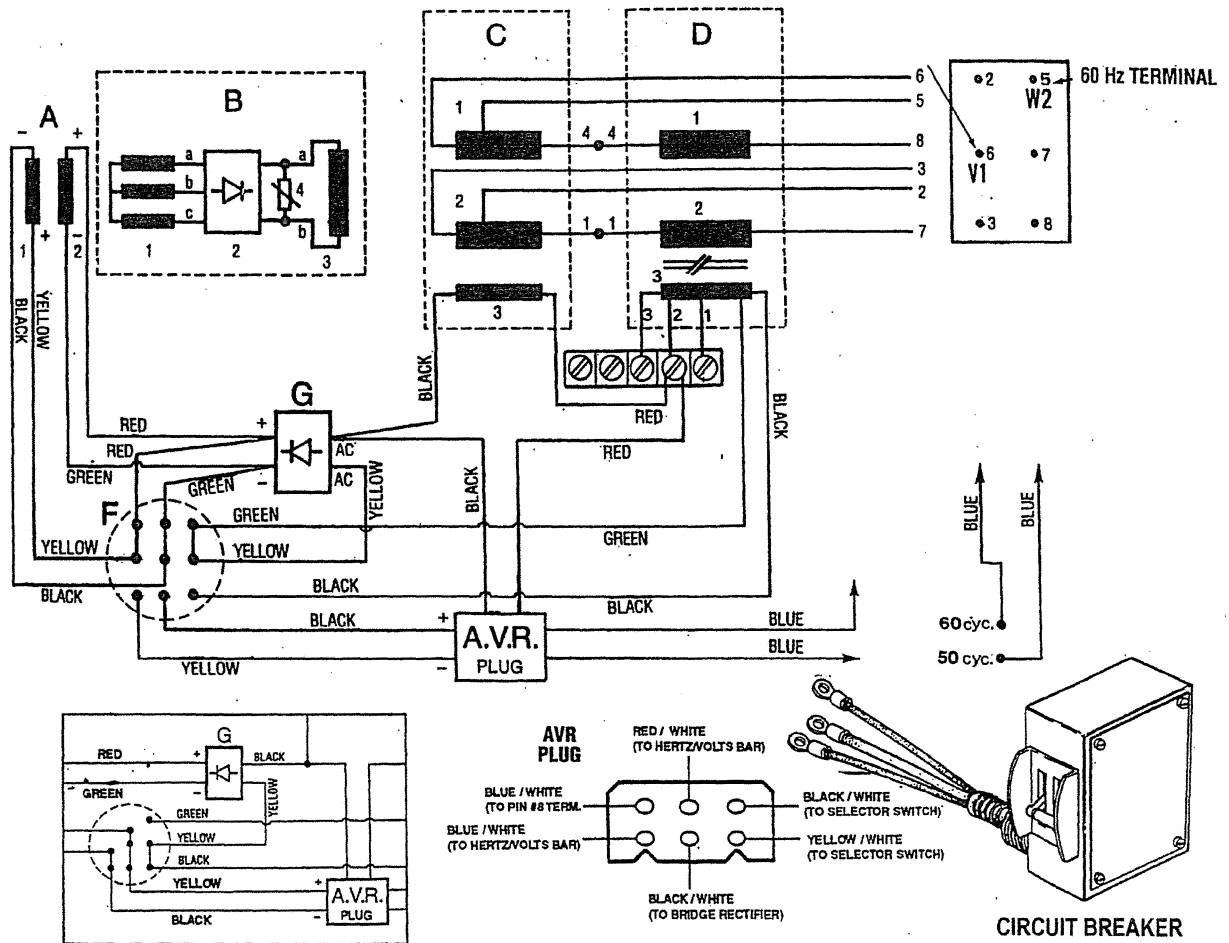

INTERNAL WIRING SCHEMATIC (SIX STUD) W/OPTIONAL VOLTAGE REGULATOR

A. EXCITER STATOR WINDINGS 1 & 2

A - 1 and A - 2 Exciter Stator Windings
(Selector in **COMP** position)

B. EXCITER ROTOR and FIELD

1. Auxiliary Windings (A - B - C)
2. Diodes (6)
3. Rotating Field Windings
4. Posi Resistor

C. MAIN STATOR

1. Main Stator Windings
2. Main Stator Windings
3. Main Stator Auxiliary Windings

D. COMPOUND TRANSFORMER

1. Compound Transformer Windings
2. Compound Transformer Windings
3. Compound Transformer Auxiliary Windings

Resistance readings and voltage checks can be accessed easily for the components in the exciter circuit A, G, C-3 and D-3 by locating the color coded wires at the connection points shown on the above schematic. When checking winding resistance values be sure to lift both of the component's electrical connections.

G. BRIDGE RECTIFIER

A.V.R.

Optional Automatic Voltage Regulator Plug (6 Prong).

GENERATOR VOLTAGE ADJUSTMENT

NOTE: WESTERBEKE recommends that the following generator tests and adjustments be performed by a qualified technician.

Generator Frequency

1. Frequency is a direct result of engine/generator speed:
1800 rpm = 60 hertz
1500 rpm = 50 hertz.
2. To change generator frequency follow the steps below.
 - a. Connect the AC output leads to the AC terminal block, following the illustrations on this page.
 - b. If an AVR is installed, reposition the blue or blue/white lead to correspond to the hertz selected on the Voltage/Hertz Connection Bar.

If there is no automatic voltage regulator (AVR) installed, do not change the wiring on the Voltage/Hertz Connection Bar. Simply reconfigure the AC terminal for the hertz change.

- c. Start the engine, monitor voltage and adjust engine no-load speed. Adjust diesel units by the linkage between the throttle arm and fuel solenoid or the throttle lever on the injection pump..

60 hertz:	no-load speed,	61.5 - 62.0 hertz.
50 hertz:	no-load speed,	51.5 - 52.0 hertz.

- d. After the no-load hertz adjustment is made, the no-load voltage may need to be readjusted. In most cases, if the generator was producing the correct no-load voltage at the previous hertz setting, it would be correct at the changed hertz setting.

In the event it needs adjustment, adjust the shim thickness under the laminated steel bar of the transformer.

- | | | |
|-----------|------------------|----------------|
| 60 hertz: | no-load voltage, | 121-124 volts. |
| 50 hertz: | no-load voltage, | 232-236 volts. |

- e. Load the generator to the rated amperage output corresponding to the hertz speed of the generator.

Rated Loaded Speed	
60 hertz:	loaded speed, 58.5 - 59.0 hertz
50 hertz:	loaded speed, 48.5 - 49.0 hertz
The lowest acceptable voltage at full rated output (amps)	
60 hertz:	108 - 110 volts
50 hertz:	205 - 210 volts

SIX STUD AC VOLTAGE CONNECTIONS

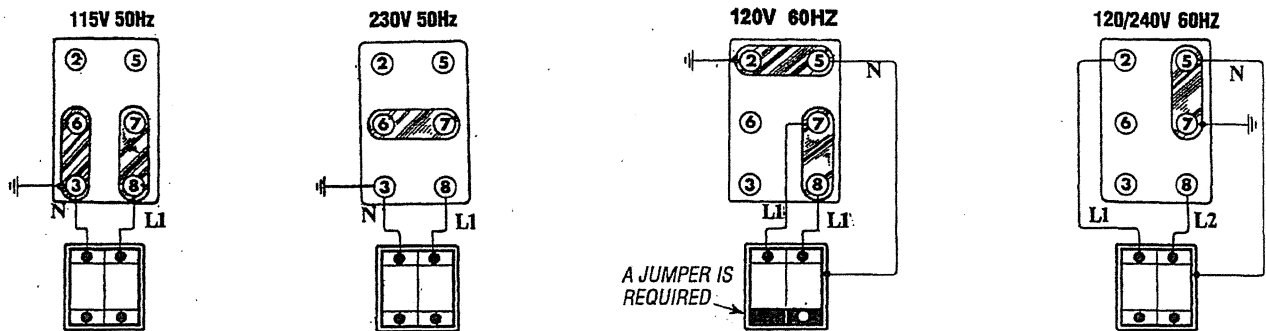

TWELVE STUD AC VOLTAGE CONNECTIONS

The frame ground wire must be moved when changing from 115 volts and 110/220 volts 50 hertz to 230 volts 50 hertz. From making connections to the AC terminal block, use terminal ends for 1/4 inch studs that will accept multi-strand copper wire sized for the amperage rating from the hot lead connection. The frame ground wire is white or white with a green strip. It connects between the neutral stud and the generator frame.

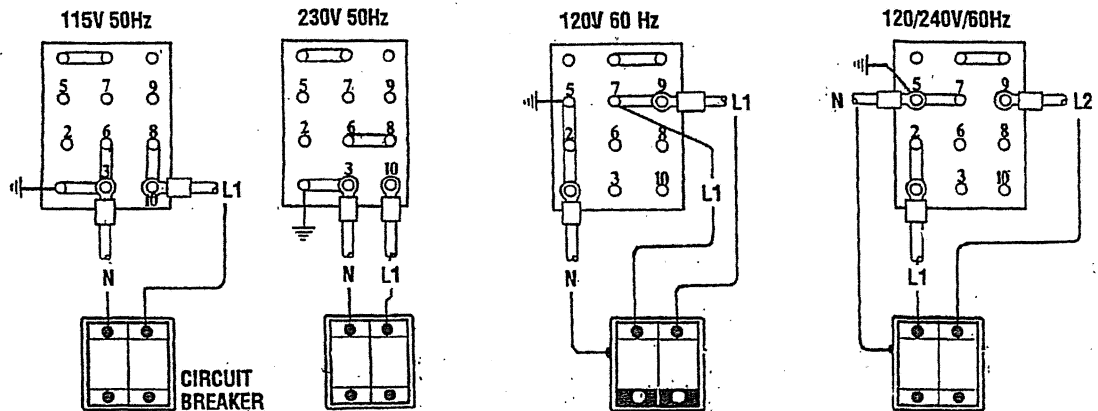

GENERATOR VOLTAGE ADJUSTMENT

NOTE: WESTERBEKE recommends that the following generator tests and adjustments be performed by a qualified technician.

NO-LOAD VOLTAGE ADJUSTMENT

Voltage adjustment is made with the generator regulation being governed by the compound transformer.

1. The selector switch, if installed, *must* be in the COMP position.
2. To confirm no-load voltage, start the generator and apply a momentary (moderate) load to excite the transformer. The voltage produced by the generator after the momentary load is removed is no-load voltage. Note the voltage output from the generators 120 volt leg(s) (230 volt 50 hertz). The no-load voltage should be between 121-124 volts at 61.5-62 hertz (232- 236 volts at 51.5-52 hertz).

NOTE: The no-load voltage should be adjusted to the voltage produced by the generator once started and a momentary load should be applied to excite the transformer and then removed. The voltage produced by the generator after this momentary load is removed is no-load voltage.

3. To raise or lower the voltage, shims of varying thickness (non-conductive material) are placed or removed from under the steel laminated bar on top of the compound transformer. The material used for shimming should not soften at temperatures in the 176° F (80° C) range. A small reduction in no-load voltage (1 to 3 volts) can some times be accomplished by gently tapping the top of the laminated steel bar to reduce the gap between the existing shims and the transformer core.

NOTE: No-load voltage may be effected needing readjustment with the compound transformer. Do not use these adjustments to compensate for overload conditions being placed on the generator/engine (inductive-motor type loads). Loss of generator hertz/speed, the result of overload, will cause a drop in voltage output.

Shim thickness of 0.001 inch will change the no-load voltage by approximately 4 - 6 volts. Adding shim material raises the no-load voltage. Removing shim material lowers no-load voltage.

FULL-LOAD VOLTAGE ADJUSTMENT

The voltage hertz connection bar that is used when changing from 60Hz to 50Hz can also be used to increase or decrease the generators full-load output.

Fine voltage adjustments can be performed by repositioning wires **A** to leads #1, #2, and #3 increasing the loaded voltage progressively in that order. A no-load voltage adjustment will have to be made as well.

Should full-load output fall below 108 volts-60Hz (210 volts-50Hz), the voltage should be adjusted.

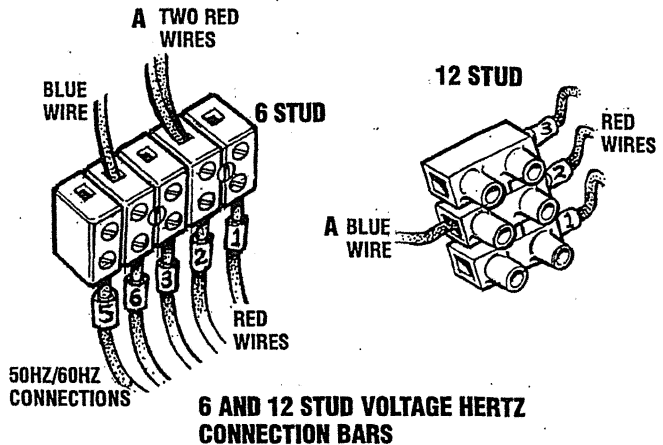

NOTE: When the optional voltage regulator is installed and if the Blue/White (Blue) lead is not correctly positioned to correspond to the Hertz, the unit is operating at, the regulator will sense incorrect voltage and cause the generator to produce abnormally high output voltage.

BT GENERATOR SINGLE PHASE

OPTIONAL AUTOMATIC VOLTAGE REGULATOR (AVR) BT 6 STUD MODELS ONLY

An optional solid-state voltage regulator (board #34410) is available for use with the BT series generators. When installed, and the regulation switch is moved to the ELEC position, the regulator works together with the standard compound transformer regulator to regulate the generator's voltage output. In the ELEC mode, the regulator provides excitation to the group 1 exciter windings, and the transformer provides excitation to the group 2 exciter windings.

Installation

1. The regulator is mounted using existing tapped holes in the generator's case. Use two (2) M4 . 07mm screws, each 15mm long, with lock washers to mount the regulator board.
2. Connect the 6-prong generator plug to the receptacle on the regulator board.

NOTE: *The plug is keyed to engage the regulator receptacle in one direction. Check this and insert it correctly.*

3. Before moving the selector switch to the ELEC position, the NO-Load voltage produced by the generator when in the COMP position will have to be adjusted. The NO-Load voltage should be adjusted down between 114 - 118 volts (60Hz) or 224 - 228 volts (50Hz) following the procedures as explained earlier in this manual.
4. With the generators no load voltage properly adjusted, move the selection switch into the ELEC position. Adjust the regulator board potentiometer to set NO-Load voltage at 120 - 122 volts at 61.5 - 62.0 Hertz (230 - 234 volts at 51.5 - 52.0 Hertz). The regulator board is operating in parallel with the compound transformer and should maintain voltage output within ± 5 per cent from NO-Load to FULL-Load.

NOTE: *Do not use the regulator to force NO-Load voltage down. Use the compound transformer for this function. Using the regulator to perform this causes the regulator to use more exciter circuit power. This leaves less exciter circuit power for loaded conditions.*

Switching Shore Power to Generator Power

CAUTION: *Heavy motor loads should be shut off before switching shore power to generator power or vice-versa because voltage surges induced by switching with heavy AC loads on the vessel being operated may cause damage to the exciter circuit components in the generator.*

BT GENERATOR TROUBLESHOOTING CHART

NOTE: *WESTERBEKE recommends that the following generator tests and adjustments be performed by a qualified technician.*

LOW VOLTAGE 60-100 VOLTS AC

COMPONENT CHECKS:

- F** SELECTOR SWITCH (6 Stud Models)
- B** ROTOR COMPONENTS
 - B2.** EXCITER ROTOR DIODES
 - B3.** ROTOR FIELD WINDING
 - B1.** EXCITER ROTOR WINDING(S) **a,b,c.**
- A** 1-1+2 EXCITER STATOR WINDING(S).

NO AC VOLTAGE OUTPUT

MAIN STATOR, ROTOR COMPONENTS, TRANSFORMER COMPONENT CHECKS:

- C** 1+2 MAIN STATOR WINDING
- B** 4 POSI RESISTOR
- B** 2 DIODES (4-6 OPEN/SHORTED)
- D** 1+2 COMPOUND TRANSFORMER WINDING
- B** 3 ROTOR FIELD WINDING

RESIDUAL VOLTAGE EXCITER CIRCUIT FAULTY

COMPONENT CHECKS:

- A** 1-1+2 EXCITER STATOR WINDING(S)
- G** BRIDGE RECTIFIER
- D** 3 TRANSFORMER AUX. WINDING
- C** 3 MAIN STATOR AUX. WINDING
- F** SELECTOR SWITCH

CIRCUIT CONNECTIONS (from the Transformer Aux. winding to the connections on the Bridge Rectifier)

BT GENERATOR INTERNAL WIRING 3 PHASE TWELVE WIRE RECONNECTABLE

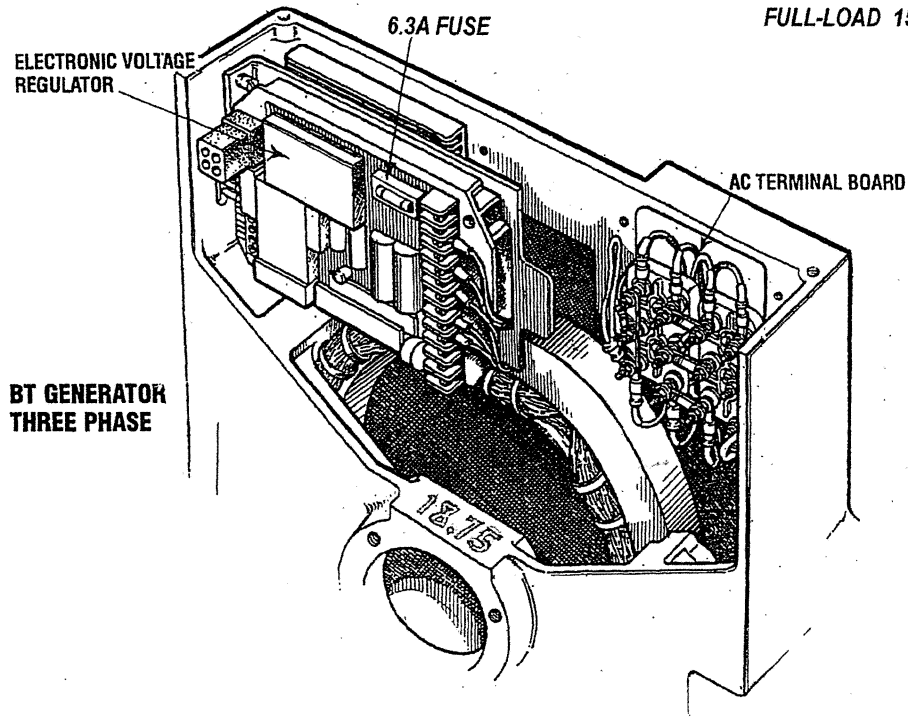
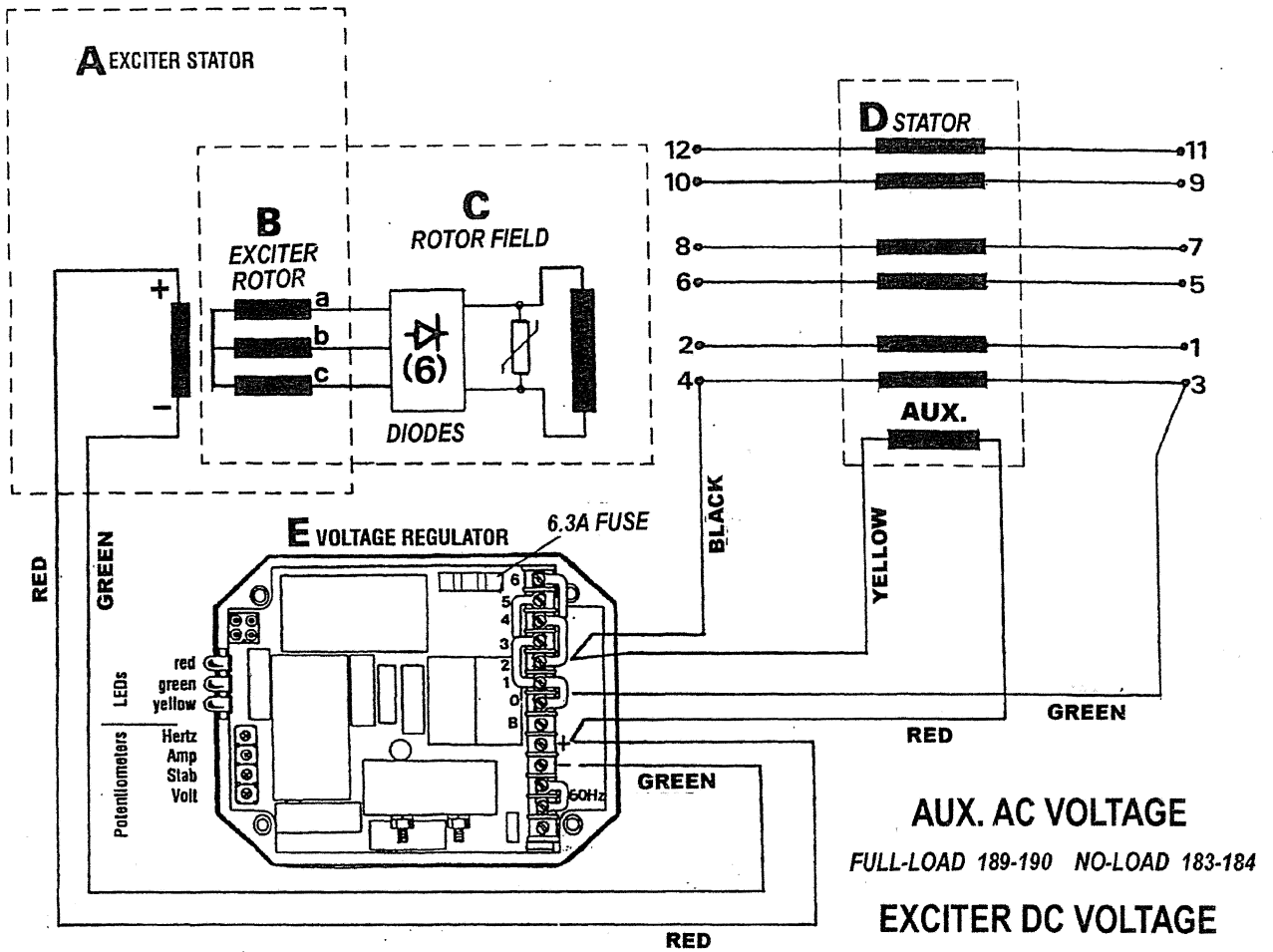

GENERATOR AC VOLTAGE CONNECTIONS

BE THREE PHASE

VOLTAGE REGULATORS THREE PHASE CONNECTIONS

The regulator is equipped with seven numbered terminals (0 to 6) and their related brass jumpers. The illustrations shown connection points and jumpers for the 3 phase configuration of the generator. The sensing leads connect between pin #1 and pin #2 on the AC terminal block and connection #2 and #0 on the voltage regulator board.

NOTE: Either Series configuration requires the installation of a jumper on the regulator board between terminal B and O.

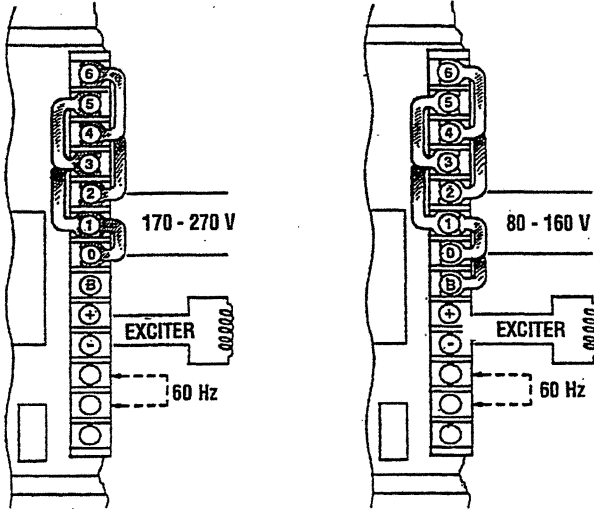

AC TERMINAL CONNECTIONS THREE PHASE 12 WIRE

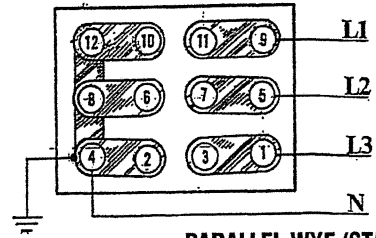

PARALLEL WYE (STAR)

L-N - 120 VAC 1Ø 60 Hz	L-L - 208 VAC 3Ø 60 Hz
L-N - 110 VAC 1Ø 50 Hz	L-L - 190 VAC 1Ø 50 Hz

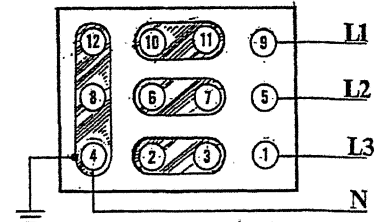

SERIES WYE (STAR)

L-L - 480 VAC 3Ø 60 Hz	L-L - 400 VAC 3Ø 50 Hz
L-N - 277 VAC 1Ø 60 Hz	L-N - 230 VAC 1Ø 50 Hz

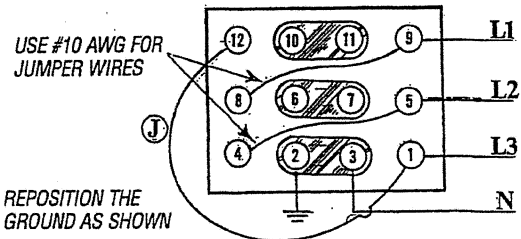

SERIES DELTA

L-L - 240 VAC 3Ø 60 Hz	L-L - 230 VAC 3Ø 50 Hz
L2, L3-N - 120 VAC 1Ø 60 Hz	L2, L3-N - 115 VAC 1Ø 50 Hz

SHORE POWER TRANSFER SWITCH

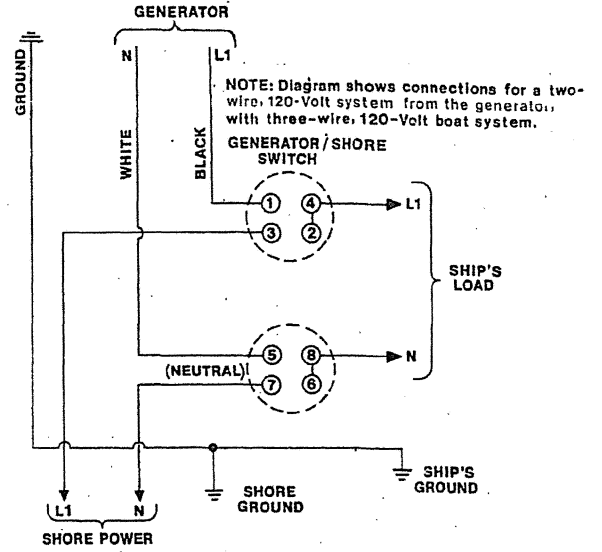
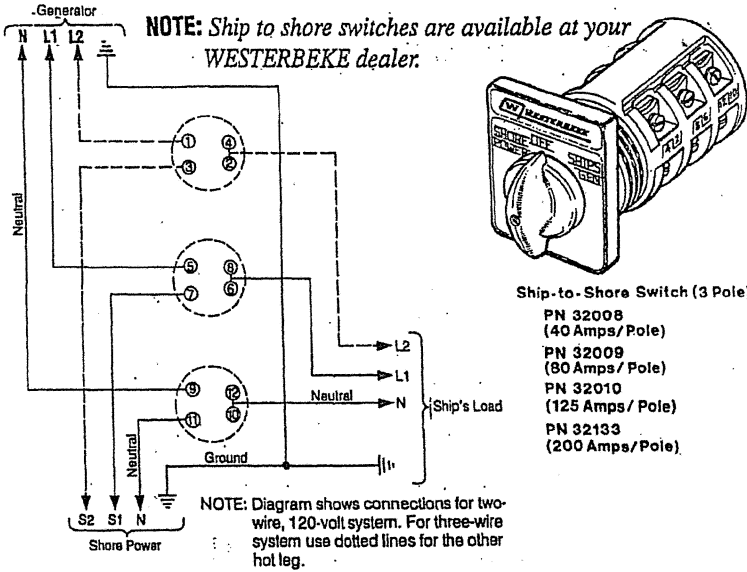

230 VOLT/50 HZ TWO WIRE CONFIGURATION

SHORE POWER CONNECTIONS (60 HERTZ)

If the installer connects shore power to the vessel's AC circuit, this must be done by means of the Shore Power Transfer Switch. Set the transfer switch shown in the diagrams to the OFF position. This switch prevents simultaneous connection of shore power to generator output.

CAUTION: Damage to the generator can result if utility shore power and generator output are connected at the same time. This type of generator damage is not covered under the warranty; it is the installer's responsibility to make sure all AC connections are correct.

Switching Shore Power to Generator Power

CAUTION: Heavy motor loads should be shut off before switching shore power to generator power or vice-versa because voltage surges induced by switching with heavy AC loads on the vessel being operated may cause damage to the exciter circuit components in the generator.

120 VOLT/60 HZ THREE WIRE CONFIGURATION

Notice the repositioning of the white wire ground load on the terminal block to the generator case.

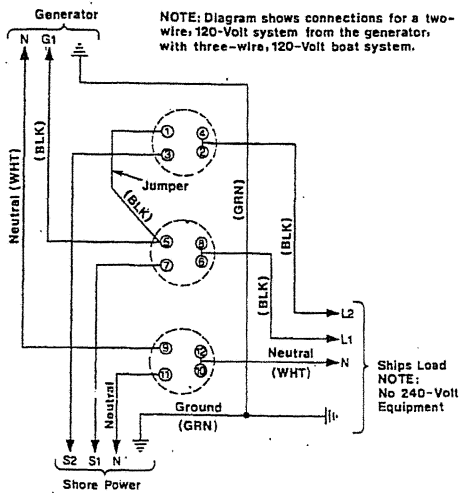

LAY-UP & RECOMMISSIONING

GENERAL

Many owners rely on their boatyards to prepare their craft, including engines and generators, for lay-up during the off-season or for long periods of inactivity. Others prefer to accomplish lay-up preparation themselves.

The procedures which follow will allow you to perform your own lay-up and recommissioning, or you may use them as a check list if others do the procedures.

These procedures should afford your engine protection during a lay-up and also help familiarize you with the maintenance needs of your engine.

If you have any questions regarding lay-up procedures, call your local servicing dealer; he will be more than willing to provide assistance.

Propeller Shaft Coupling [Propulsion Engine]

The transmission and propeller half couplings should always be opened up and the bolts removed when the boat is hauled out of the water or moved from land to water, and during storage in the cradle. The flexibility of the boat often puts a severe strain on the propeller shaft or coupling or both, while the boat is taken out or put in the water. In some cases, the shaft has actually been bent by these strains. This does not apply to small boats that are hauled out of the water when not in use, unless they have been dry for a considerable period of time.

Fresh Water Cooling Circuit [Propulsion Engine]

A 50-50 solution of antifreeze and distilled water is recommended for use in the coolant system at all times. This solution may require a higher concentration of antifreeze, depending on the area's winter climate. Check the solution to make sure the antifreeze protection is adequate.

Should more antifreeze be needed, drain an appropriate amount from the engine block and add a more concentrated mixture. Operate the engine to ensure a complete circulation and mixture of the antifreeze concentration throughout the cooling system. Now recheck the antifreeze solution's strength.

Lubrication System

With the engine warm, drain all the engine oil from the oil sump. Remove and replace the oil filter and fill the sump with new oil. Use the correct grade of oil. Refer to the *ENGINE LUBRICATING OIL* pages in this manual for the oil changing procedure. Run the engine and check for proper oil pressure and make sure there are no leaks.

CAUTION: Do not leave the engine's old engine oil in the sump over the lay-up period. Lubricating oil and combustion deposits combine to produce harmful chemicals which can reduce the life of your engine's internal parts.

Fuel System [Gasoline]

Top off your fuel tanks with *unleaded* gasoline of 89 octane or higher. A fuel conditioner such as *Sta-Bil* gasoline stabilizer should be added. Change the element in your gasoline/water separator and clean the metal bowl. Re-install and make certain there are no leaks. Clean up any spilled fuel.

Fuel System [Diesel]

Top off your fuel tanks with No. 2 diesel fuel. Fuel additives such as *BioBor* and *Diesel Kleen + Cetane Boost* should be added at this time to control algae and condition the fuel. Care should be taken that the additives used are compatible with the primary fuel filter/water separator used in the system. Change the element in your primary fuel filter/water separator, if the fuel system has one, and clean the separator sediment bowl.

Change the fuel filter elements on the engine and bleed the fuel system, as needed. Start the engine and allow it to run for 5 – 10 minutes to make sure no air is left in the fuel system. Check for any leaks that may have been created in the fuel system during this servicing, correcting them as needed. Operating the engine for 5 – 10 minutes will help allow movement of the treated fuel through the injection equipment on the engine.

Raw Water Cooling Circuit

Close the through-hull seacock. Remove the raw water intake hose from the seacock. Place the end of this hose into a five gallon bucket of clean fresh water. Before starting the engine, check the zinc anode found in the primary heat exchanger on the engine and clean or replace it as required, and also clean any zinc debris from inside the heat exchanger where the zinc anode is located. Clean the raw water strainer.

Start the engine and allow the raw water pump to draw the fresh water through the system. When the bucket is empty, stop the engine and refill the bucket with an antifreeze solution slightly stronger than needed for winter freeze protection in your area.

Start the engine and allow all of this mixture to be drawn through the raw water system. Once the bucket is empty, stop the engine. This antifreeze mixture should protect the raw water circuit from freezing during the winter lay-up, as well as providing corrosion protection.

Remove the impeller from your raw water pump (some antifreeze mixture will accompany it, so catch it in a bucket). Examine the impeller. Acquire a replacement, if needed, and a cover gasket. Do not replace the impeller (into the pump) until recommissioning, but replace the cover and gasket.

Intake Manifold and Thru-Hull Exhaust

Place a clean cloth, lightly soaked in lubricating oil, in the opening of the intake manifold to block the opening. Do not shove the cloth out of sight. (If it is not visible at recommissioning, and an attempt is made to start the engine, you may need assistance of the servicing dealer. Make a note to remove the cloth prior to start-up. The thru-hull exhaust port can be blocked in the same manner.

LAY-UP & RECOMMISSIONING

Starter Motor

Lubrication and cleaning of the starter drive pinion is advisable, if access to the starter permits its easy removal. Make sure the battery connections are shut off before attempting to remove the starter. Take care in properly replacing any electrical connections removed from the starter.

Cylinder Lubrication [Diesel]

If you anticipate a long lay-up period (12 months or more) WESTERBEKE recommends removal of the glow plugs for access to the cylinders. Squirt some Marvel Mystery Oil into the cylinder walls. Rotate the engine crankshaft by hand two revolutions and re-install the glow plugs.

If your engine does not have glow plugs, the injectors will have to be removed. Be sure to have replacement sealing washers for the injectors and return fuel line as needed.

Intake Manifold [Gasoline]

Clean the filter screen in the flame arrester, and place a clean cloth lightly soaked in lube oil around the flame arrester to block any opening. Also place an oil-soaked cloth in the through-hull exhaust port. Make a note to remove cloths prior to start-up!

Cylinder Lubrication [Gasoline]

After engine shutdown, remove the spark plugs and spray a small amount of fogging oil into each cylinder. Rotate the crankshaft manually two complete revolutions. Re-install the spark plugs loosely for winter lay-up

NOTE: At spring commissioning, remove the plugs and rotate the crankshaft two full revolutions. Re-install the spark plugs, tighten properly and connect the high tension leads fully onto each spark plug.

Batteries

If batteries are to be left on board during the lay-up period, make sure that they are fully charged, and will remain that way, to prevent them from freezing. If there is any doubt that the batteries will not remain fully charged, or that they will be subjected to severe environmental conditions, remove the batteries and store them in a warmer, more compatible environment.

WARNING: Lead acid batteries emit hydrogen, a highly-explosive gas, which can be ignited by electrical arcing or a lighted cigarette, cigar, or pipe. Do not smoke or allow an open flame near the battery being serviced. Shut off all electrical equipment in the vicinity to prevent electrical arcing during servicing.

Transmission [Propulsion Engine]

Check or change the fluid in the transmission as required. Wipe off grime and grease and touch up any unpainted areas. Protect the coupling and the output flange with an anti-corrosion coating. Check that the transmission vent is open. For additional information, refer to the TRANSMISSION SECTION.

Spare Parts

Lay-up time provides a good opportunity to inspect your Westerbeke engine to see if external items such as drive belts or coolant hoses need replacement. Check your basic spares kit and order items not on hand, or replace those items used during the lay-up, such as filters and zinc anodes. Refer to the SPARE PARTS section of this manual.

Recommissioning

The recommissioning of your Westerbeke engine after a seasonal lay-up generally follows the same procedures as those described in the PREPARATIONS FOR STARTING section regarding preparation for starting and normal starts. However, some of the lay-up procedures will need to be counteracted before starting the engine.

1. Remove the oil-soaked cloths from the intake manifold.
2. Remove the raw water pump cover and gasket and discard the old gasket. Install the raw water pump impeller removed during lay-up (or a replacement, if required). Install the raw water pump cover with a new cover gasket.
3. Reinstall the batteries that were removed during the lay-up, and reconnect the battery cables, making sure the terminals are clean and that the connections are tight. Check to make sure that the batteries are fully charged.

CAUTION: Wear rubber gloves, a rubber apron, and eye protection when servicing batteries. Lead acid batteries emit hydrogen, a highly explosive gas, which can be ignited by electrical arcing or a lighted cigarette, cigar, or pipe. Do not smoke or allow an open flame near the battery being serviced. Shut off all electrical equipment in the vicinity to prevent electrical arcing during servicing.

4. Remove the spark plugs, wipe clean, re-gap, and install to proper tightness [gasoline].
5. Check the condition of the zinc anode in the raw water circuit and clean or replace the anode as needed. Note that it is not necessary to flush the antifreeze/fresh water solution from the raw water coolant system. When the engine is put into operation, the system will self-flush in a short period of time with no adverse affects. It is advisable, as either an end of season or recommissioning service, to inspect the area where the zinc is located in the heat exchanger and clear any and all zinc debris from that area.
6. Start the engine in accordance with procedures described in the PREPARATIONS FOR STARTING section of this manual.

SPECIFICATIONS 11.5 EGTD, 11.0 EGTD, 10.0 EGTD, 8.0 EGTD

GENERAL

Engine Type	Diesel, four-cycle, three-cylinder, fresh water-cooled, vertical in-line overhead valve mechanism.	
Displacement	80.4 cubic inches (1.318 liter)	
Aspiration	Naturally aspirated.	
Combustion Chamber	Swirl type.	
Bore & Stroke	3.07 x 3.62 inches (78 x 92 mm)	
Firing Order	1 - 3 - 2	
Direction of Rotation	Clockwise, when viewed from the front.	
Compression Ratio	22:1	
Weight	8.0 EGTD	467 lbs (211.8 kilos)
	10.0 EGTD	513 lbs (232.7 kilos)
	11.0 EGTD	513 lbs (232.7 kilos)
	11.5 EGTD	513 lbs (232.7 kilos)
Inclination	Continuous 15° Temporary 25° (not to exceed 30 min.)	
Engine Combustion Air Requirements @ 60Hz 1800 rpm	41 cfm (1.16 cmm)	

TUNE-UP SPECIFICATIONS

Compression Pressure Minimum	427 psi (30 kg/cm ²) at 280 rpm 384 psi (27 kg/cm ²)
Spilled Timing (Static)	17° (spill)
Valve Seat Angle	45°
Engine Timing	17° BTDC
Injector Pressure	1991 + 71 - 0 psi (140 + 5 - 0 kgf/cm ²).
Valve Seat Angle	Intake 45° Exhaust 30°
Valve Clearance (engine cold)	0.25mm (0.0098in)

LUBRICATION SYSTEM

General	Pressure fed system.
Oil Filter	Full flow, paper element, spin-on type.
Sump Capacity (not including filter)	3.9 U.S. qts (3.7 liters)
Operating Oil Pressure (engine hot)	50 - 60 psi (3.5 - 4.2 kg/cm ²)
Oil Grade	API Specification CF, CG-4, CI-4 or CJ-4 SAE 10W-40 or 15W-40.

FUEL SYSTEM

General	Open flow, self priming.
Fuel	No. 2-D (Cetane rating of 45 or higher). SAE J313. Grade of diesel fuel according to ASTM D975.
Fuel Injection Pump	In-line plunger type (BOSCH).
Nozzle	Throttle type.
Fuel Filter	Cartridge Type
Air cleaner	Replaceable paper filter cartridge.
Fuel Lift Pump	12 volt DC lift capacity of 5' (1.5 mm) solid state

ELECTRICAL SYSTEM

Starting Battery	12 Volt, (-) negative ground
Battery Capacity	400 - 600 Cold Cranking Amps (CCA)
DC Charging Alternator	51 Amp rated, belt-driven
Starting Aid	Glow plugs, sheathed type
Starter	12 Volt, reduction gear

COOLING SYSTEM

General	Fresh water-cooled block, thermostatically-controlled with heat exchanger.
Operating Temperature	170° - 190° F (77° - 88° C)
Fresh Water Pump	Centrifugal type, metal impeller, belt-driven.
Raw Water Pump	Positive displacement, rubber impeller, belt-driven.
Raw Water Flow at 1800 rpm. (Measured before discharging into exhaust elbow).	7-8 gpm (25.9 - 29.6 gpm).
System Capacity (Fresh Water)	5.0 US qts (4.7 liters)

SPECIFICATIONS 8.0 EGTD

AC GENERATOR (Single Phase)	
Single Phase	Brushless, four-pole, revolving field. Pre-lubricated, single bearing design. Reconnectable, single phase transformer regulation (optional solid-state voltage regulation).
Voltage	120 or 120/240 Volts - 60 Hertz 230 Volts - 50 Hertz
Voltage regulation:	± 5% no load to full load.
Frequency regulation:	.5 Hertz (.6%) no load to full load.
Rating (Volts AC)	
60 Hertz (1800 rpm) 8.0 KW	120 Volts 66 Amps 120/240 Volts 66/33 Amps
50 Hertz (1500 rpm) 6.0 KW	230 Volts 27 Amps
Generator Cooling Air Requirements (60 Hertz) at 1800 rpm	175 - 200 cfm (4.95-5.66 cmm) NOTE: Increase air supply 15% for 50 Hertz operation (1500 rpm)
Engine Combustion Air Requirements	42 cfm (1.19 cmm)
Engine Compartments Cooling Air	100 - 200 cfm (2.83-5.66 cmm)
Generator Compartment Ambient Temperature Recommendations	122°F (50°C) maximum NOTE: Forced ventilation should be provided to maintain generator compartment temperature below 122°F (50°C)

SPECIFICATIONS 10.0 EGTD

AC GENERATOR (Single Phase)	
Single Phase	Brushless, four-pole, revolving field. Pre-lubricated, single bearing design. Reconnectable, single phase transformer regulation (optional solid-state voltage regulation).
Voltage	120 or 120/240 Volts - 60 Hertz 230 Volts - 50 Hertz
Voltage regulation:	± 5% no load to full load.
Frequency regulation:	.5 Hertz (.6%) no load to full load.
Rating (Volts AC)	
60 Hertz (1800 rpm) 10.0 KW	120 Volts 83.3 Amps 120/240 Volts 83.3/41.6 Amps
50 Hertz (1500 rpm) 7.5 KW	230 Volts 34.1 Amps
Generator Cooling Air Requirements (60 Hertz) at 1800 rpm	225 - 250 cfm (5.66-6.37 cmm) NOTE: Increase air supply 15% for 50 Hertz operation (1500 rpm)
Engine Combustion Air Requirements	42 cfm (1.19 cmm)
Engine Compartments Cooling Air	100 - 200 cfm (2.83-5.66 cmm)
Generator Compartment Ambient Temperature Recommendations	122°F (50°C) maximum NOTE: Forced ventilation should be provided to maintain generator compartment temperature below 122°F (50°C)

AC GENERATOR (3 Phase)		
General - 3 Phase	Brushless six pole, revolving field. Sealed lubricated single bearing design. 12 Lead reconnectable for low voltage WYE, high voltage Delta. Solid State voltage regulator with protection circuitry.	
10.0 KW - 60 Hertz 7.5 KW - 50 Hertz		
Voltage - 3 Phase (60 Hertz)	Low voltage WYE	208 volts
	High voltage WYE	480 volts
	DELTA	240 volts
Voltage - 3 Phase (50 Hertz)	High voltage WYE	380 volts
	DELTA	230 volts
Amperage - 3 Phase (60 Hertz)	Low voltage WYE	35 Amps
	High voltage WYE	15 Amps
	DELTA	30 Amps
Amperage - 3 Phase (50 Hertz)	High voltage WYE	14 Amps
	DELTA	24 Amps
Generator Cooling Air Requirements (60 Hertz) at 1800 rpm	225 - 250 cfm (5.66 - 6.37 cmm) NOTE: Increase air supply 15% for 50 Hertz operation (1500 rpm)	
Engine Combustion Air Requirements	42 cfm (1.19 cmm)	
Engine Compartments Cooling Air	100 - 200 cfm (2.83-5.66 cmm)	
Generator Compartment Ambient Temperature Recommendations	122°F (50°C) maximum NOTE: Forced ventilation should be provided to maintain generator compartment temperature below 122°F (50°C)	

SPECIFICATIONS 11.0 EGTD

AC GENERATOR (Single Phase)	
Single Phase	Brushless, four-pole, revolving field. Pre-lubricated, single bearing design. Reconnectable, single phase transformer regulation (optional solid-state voltage regulation).
Voltage	120 or 120/240 Volts - 60 Hertz 230 Volts - 50 Hertz
Voltage regulation:	± 5% no load to full load.
Frequency regulation:	.5 Hertz (.60%) no load to full load.
Rating (Volts AC)	
60 Hertz (1800 rpm) 11.0 KW	120 Volts 91.7 Amps 120/240 Volts 91.7/45.8 Amps
50 Hertz (1500 rpm) 8.8 KW	230 Volts 38.3 Amps
Generator Cooling Air Requirements (60 Hertz) at 1800 rpm	225 - 250 cfm (5.66-6.37 cmm) NOTE: Increase air supply 15% for 50 Hertz operation (1500 rpm)
Generator Compartment Ambient Temperature Recommendations	122°F (50°C) maximum NOTE: Forced ventilation should be provided to maintain generator compartment temperature below 122°F (50°C).

AC GENERATOR (3 Phase)		
General - 3 Phase	Brushless six pole, revolving field. Sealed lubricated single bearing design. 12 Lead reconnectable for low voltage WYE, high voltage Delta. Solid State voltage regulator with protection circuitry.	
11.0 KW - 60 Hertz 8.8 KW - 50 Hertz		
Voltage - 3 Phase (60 Hertz).	Low voltage WYE	208 volts
	High voltage WYE	480 volts
	DELTA	240 volts
Voltage - 3 Phase (50 Hertz)	High voltage WYE	400 volts
	DELTA	230 volts
Amperage - 3 Phase (60 Hertz)	Low voltage WYE	37 Amps
	High voltage WYE	16 Amps
	DELTA	33 Amps
Amperage - 3 Phase (50 Hertz)	High voltage WYE	15 Amps
	DELTA	27 Amps
Generator Cooling Air Requirements (60 Hertz) at 1800 rpm	225 - 250 cfm (5.66 - 6.37 cmm) NOTE: Increase air supply 15% for 50 Hertz operation (1500 rpm)	
Generator Compartment Ambient Temperature Recommendations	122°F (50°C) maximum NOTE: Forced ventilation should be provided to maintain generator compartment temperature below 122°F (50°C).	

SPECIFICATIONS 11.5 EGTD

AC GENERATOR (Single Phase)	
Single Phase	Brushless, four-pole, revolving field. Pre-lubricated, single bearing design. Reconnectable, single phase transformer regulation (optional solid-state voltage regulation).
Voltage	120 or 120/240 Volts - 60 Hertz 230 Volts - 50 Hertz
Voltage regulation:	± 5% no load to full load.
Frequency regulation:	.5 Hertz (.6%) no load to full load.
Rating (Volts AC)	
60 Hertz (1800 rpm) 11.5KW	120 Volts 95.8 Amps 120/240 Volts 95.8/47.0 Amps
50 Hertz (1500 rpm) 9.2KW	230 Volts 40 Amps
Generator Cooling Air Requirements (60 Hertz) at 1800 rpm	225 - 250 cfm (5.66 - 6.37 cmm) NOTE: Increase air supply 15% for 50 Hertz operation (1500 rpm)
Generator Compartment Ambient Temperature Recommendations	122°F (50°C) maximum NOTE: Forced ventilation should be provided to maintain generator compartment temperature below 122°F (50°C)

AC GENERATOR (3 Phase)		
General - 3 Phase	Brushless six pole, revolving field. Sealed lubricated single bearing design. 12 Lead reconnectable for low voltage WYE, high voltage Delta. Solid State voltage regulator with protection circuitry.	
11.5 KW - 60 Hertz 9.2 KW - 50 Hertz		
Voltage - 3 Phase (60 Hertz)	Low voltage WYE	208 volts
	High voltage WYE	480 volts
	DELTA	240 volts
Voltage - 3 Phase (50 Hertz)	High voltage WYE	380 volts
	DELTA	230 volts
Amperage - 3 Phase (60 Hertz)	Low voltage WYE	43 Amps
	High voltage WYE	17 Amps
	DELTA	37 Amps
Amperage - 3 Phase (50 Hertz)	High voltage WYE	17 Amps
	DELTA	30 Amps
Generator Cooling Air Requirements (60 Hertz) at 1800 rpm	225 - 250 cfm (5.66 - 6.37 cmm) NOTE: Increase air supply 15% for 50 Hertz operation (1500 rpm)	
Generator Compartment Ambient Temperature Recommendations	122°F (50°C) maximum NOTE: Forced ventilation should be provided to maintain generator compartment temperature below 122°F (50°C)	

SPECIFICATIONS 12.5 EGTD AND 15 EGTD

GENERAL	
Engine Type	Diesel, four-cycle, four-cylinder, fresh water-cooled, vertical in-line overhead valve mechanism.
Displacement	107.3 cubic inches (1.758 liter)
Aspiration	Naturally aspirated.
Combustion Chamber	Swirl type.
Bore & Stroke	3.07 x 3.62 inches (78 x 92 mm)
Firing Order	1 - 3 - 4 - 2
Direction of Rotation	Clockwise, when viewed from the front.
Compression Ratio	22:1
Dimensions - inches (mm)	Height: 24.0 inches (609.6 mm)
Engine Only	Width: 19.0 inches (482.6 mm) Length: 34.6 inches (878.8 mm)
Weight (dry)	569 lbs (258.10 kgs)
Fuel Consumption	1.42 g/hr (5.38 ltr/hr) at 1800 rpm
HP @ 1800 RPM	25 HP
HP @ 1500 PRM	21 HP
TUNE-UP SPECIFICATIONS	
Compression Pressure	427 psi (30 kg/cm ²) at 280 rpm
Minimum	384 psi (27 kg/cm ²)
Spilled Timing (Static)	17° (spill)
Valve Seat Angle	Intake 45° Exhaust 30°
Engine Speed	1800 rpm (60 Hz) 1500 rpm (50 Hz)
Valve Clearance	0.25 inches (0.0098 mm)
Injector Pressure	1991 + 71 - 0 psi (140 + 5 - 0 kgf/cm ²).
Engine Timing	17° BTDC
ELECTRICAL SYSTEM	
Starting Battery	12 Volt, (-) negative ground
Battery Capacity	400 - 600 Cold Cranking Amps (CCA)
DC Charging Alternator	51 Amp rated, belt-driven
Starting Aid	Glow plugs, sheathed type
Starter	12 Volt, reduction gear
Cold Cranking Amp Draw	175 - 200 amps (approximate)

FUEL SYSTEM	
General	Open flow, self priming.
Fuel	No. 2-D (Cetane rating of 45 or higher). SAE J313. Grade of diesel fuel according to ASTM D975.
Fuel Injection Pump	In-line plunger type (BOSCH).
Nozzle	Throttle type.
Fuel Filter	Cartridge Type (PN#030200)
Air cleaner	Replaceable paper filter cartridge.
Fuel Lift Pump	12 volt DC lift capacity of 5' (1.5 mm) solid state
COOLING SYSTEM	
General	Fresh water-cooled block, thermostatically-controlled with heat exchanger.
Operating Temperature	170° - 190° F (77° - 88° C)
Fresh Water Pump	Centrifugal type, metal impeller, belt-driven.
Raw Water Pump	Positive displacement, rubber impeller, belt-driven.
System Capacity (Fresh Water)	8.0 US qts (7.6 liters)
Raw Water Flow at 1800 rpm. (Measured before discharging into exhaust elbow).	7-8 gpm (25.9 - 29.6 gpm).
Engine Combustion Air Requirements @ 60Hz 1800 rpm	41 cfm (1.16 cmm)
LUBRICATION SYSTEM	
General	Pressure fed system.
Oil Filter	Full flow, paper element, spin-on type.
Sump Capacity (not including filter)	4.5 U.S. qts (4.3 liters)
Operating Oil Pressure (engine hot)	50 - 60 psi (3.5 - 4.2 kg/cm ²)
Oil Grade	API Specification CF, CG-4, CI-4 or CJ-4 SAE 10W-40 or 15W-40.

SPECIFICATIONS 12.5 EGTD

AC GENERATOR (Single Phase)	
Single Phase	Brushless, four-pole, revolving field. Pre-lubricated, single bearing design. Reconnectable, single phase transformer regulation (optional solid-state voltage regulation).
Voltage	120 or 120/240 Volts - 60 Hertz 230 Volts - 50 Hertz
Voltage regulation:	± 5% no load to full load.
Frequency regulation:	.5 Hertz (.6%) no load to full load.
Rating (Volts AC)	
60 Hertz (1800 rpm)	120 Volts 104 Amps 120/240 Volts 104/52 Amps
12.5KW	
50 Hertz (1500 rpm)	230 Volts 60 Amps
9.3KW	
Generator Cooling Air Requirements (60 Hertz) at 1800 rpm	225 - 250 cfm (5.66 - 6.37 cmm) NOTE: Increase air supply 15% for 50 Hertz operation (1500 rpm)
Generator Compartment Ambient Temperature Recommendations	122°F (50°C) maximum NOTE: Forced ventilation should be provided to maintain generator compartment temperature below 122°F (50°C)

AC GENERATOR (3 Phase)		
General - 3 Phase	Brushless six pole, revolving field. Sealed lubricated single bearing design. 12 Lead reconnectable for low voltage WYE, high voltage Delta. Solid State voltage regulator with protection circuitry.	
12.5 KW - 60 Hertz		
9.3 KW - 50 Hertz		
Voltage - 3 Phase (60 Hertz)	Low voltage WYE	208 volts
	High voltage WYE	480 volts
	DELTA	240 volts
Voltage - 3 Phase (50 Hertz)	High voltage WYE	380 volts
	DELTA	230 volts
Amperage - 3 Phase (60 Hertz)	Low voltage WYE	43 Amps
	High voltage WYE	17 Amps
	DELTA	37 Amps
Amperage - 3 Phase (50 Hertz)	High voltage WYE	17 Amps
	DELTA	30 Amps
Generator Cooling Air Requirements (60 Hertz) at 1800 rpm	225 - 250 cfm (5.66 - 6.37 cmm) NOTE: Increase air supply 15% for 50 Hertz operation (1500 rpm)	
Generator Compartment Ambient Temperature Recommendations	122°F (50°C) maximum NOTE: Forced ventilation should be provided to maintain generator compartment temperature below 122°F (50°C)	

SPECIFICATIONS 15 EGTD

AC GENERATOR (Single Phase)	
Single Phase	Brushless, four-pole, revolving field. Pre-lubricated, single bearing design. Reconnectable, single phase transformer regulation (optional solid-state voltage regulation)..
Voltage	120 or 120/240 Volts - 60 Hertz 230 Volts - 50 Hertz
Voltage regulation:	± 5% no load to full load.
Frequency regulation:	± 3 Hertz (5%) no load to full load. (Electronic Governered) Non-Electric ±3 Hertz
Rating (Volts AC)	
60 Hertz (1800 rpm)	120 Volts 125 Amps 120/240 Volts 195.8/49.9 Amps
50 Hertz (1500 rpm)	230 Volts 60 Amps
Generator Cooling Air Requirements (60 Hertz) at 1800 rpm	225 - 250 cfm (6.37 - 705 cmm) NOTE: Increase air supply 15% for 50 Hertz operation (1500 rpm)
Engine Combustion Air Requirements @ 60Hz 1800 rpm	46 cfm (1.9 cmm)
Generator Compartment Ambient Temperature Recommendations	122°F (50°C) maximum NOTE: Forced ventilation should be provided to maintain generator compartment temperature below 122°F (50°C)

AC GENERATOR (3 Phase)		
General - 3 Phase	Brushless six pole, revolving field. Sealed lubricated single bearing design. 12 Lead reconnectable for low voltage WYE, high voltage Delta. Solid State voltage regulator with protection circuitry.	
15.0 KW - 60 Hertz		
12.0 KW - 50 Hertz		
Voltage - 3 Phase (60 Hertz)	Low voltage WYE	208 volts
	High voltage WYE	480 volts
	DELTA	240 volts
Voltage - 3 Phase (50 Hertz)	High voltage WYE	400 volts
	DELTA	230 volts
Amperage - 3 Phase (60 Hertz)	Low voltage WYE	52 Amps
	High voltage WYE	22 Amps
	DELTA	45 Amps
Amperage - 3 Phase (50 Hertz)	High voltage WYE	22 Amps
	DELTA	39 Amps
Generator Compartment Ambient Temperature Recommendations	122°F (50°C) maximum NOTE: Forced ventilation should be provided to maintain generator compartment temperature below 122°F (50°C)	

WIRING SCHEMATIC #56225

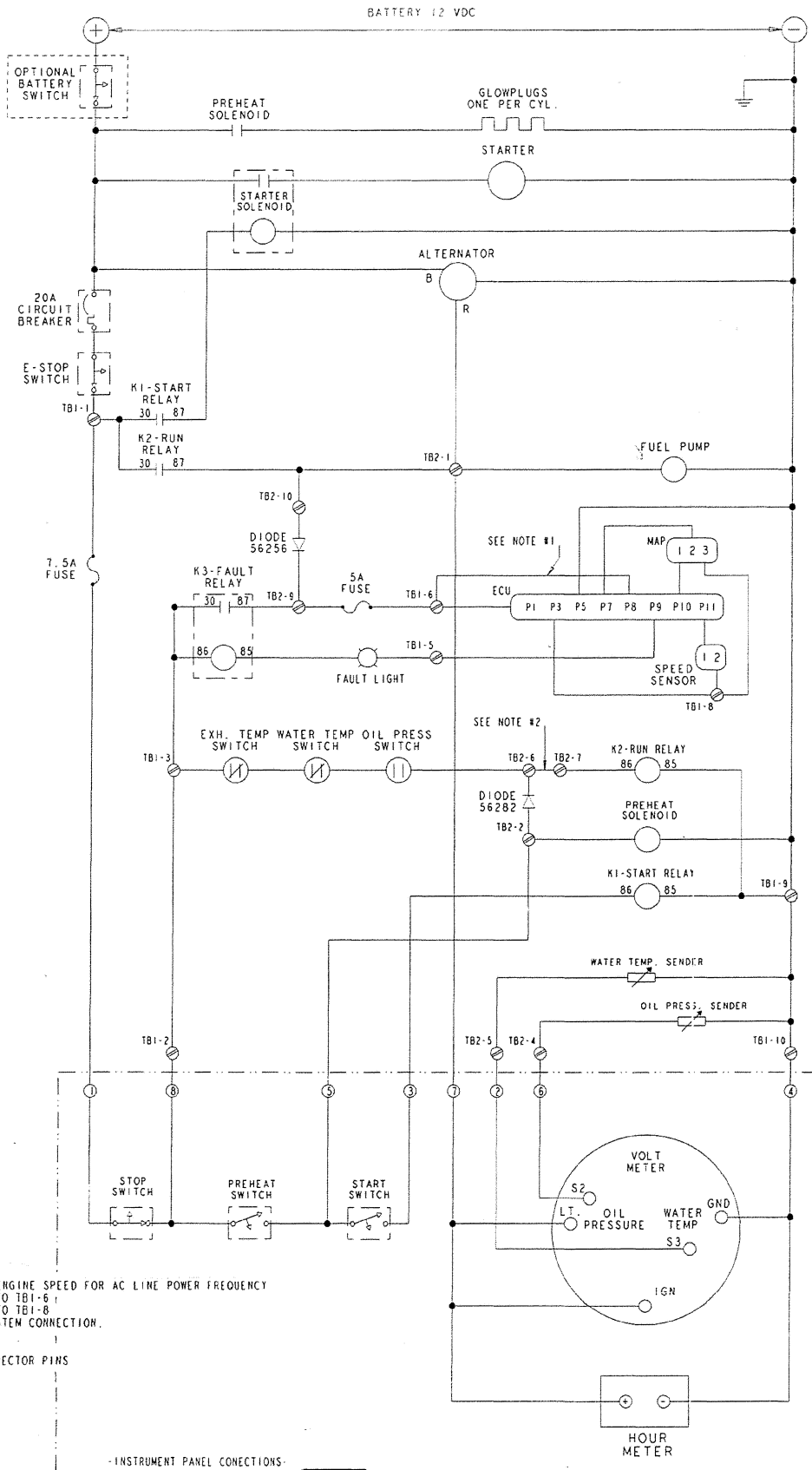

WATER HEATER (OWNERS OPTION) INSTALLATION INSTRUCTIONS

INSTALLATION

This engine is equipped with connections for the plumbing of engine coolant to transfer heat to an on-board water heater. The water heater should be mounted in a convenient location either in a high or low position in relation to the engine, so that the connecting hoses from the heater to the engine can run in a reasonably direct line without any loops which might trap air.

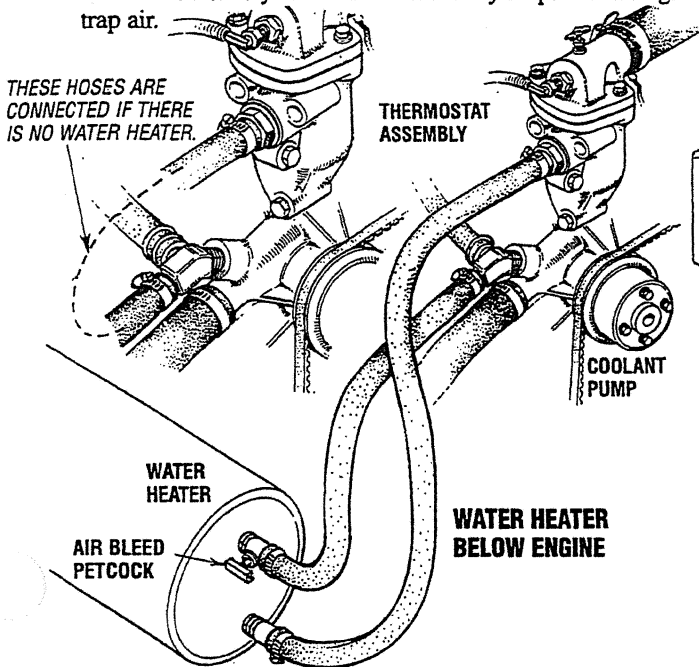

The pressure cap on the engine's manifold should be installed after the engine's cooling system is filled with coolant. Finish filling the cooling system from the remote tank after the system is filled and is free of air and exhibits good coolant circulation. During engine operation, checking the engine's coolant should be done at the remote tank and not at the engine manifold cap. The hose connection from the heater to the remote expansion tank should be routed and supported so it rises continuously from the heater to the tank, enabling any air in the system to rise up to the tank and out of the system.

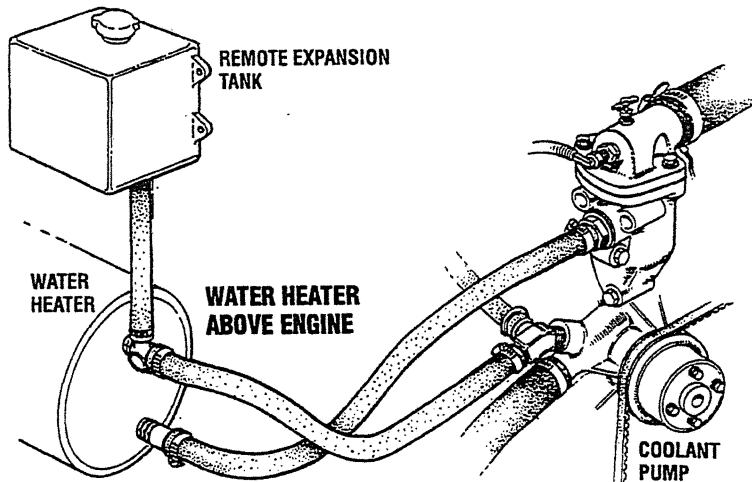

Hoses should rise continuously from their low point at the heater to the engine so that air will rise naturally from the heater to the engine. If trapped air is able to rise to the heater, then an air bleed petcock must be installed at the higher fitting on the heater for bleeding air while filling the system.

NOTE: If any portion of the heating circuit rises above the engine's own pressure cap, then a pressurized (aluminum) remote expansion tank (Kit #024177) must be installed in the circuit to become the highest point. Tee the remote expansion tank into the heater circuit, choosing the higher of the two connections for the return. Tee at the heater, and plumb a single line up to the tank's location and the other back to the engine's return. Install the remote expansion tank in a convenient location so the coolant level can easily be checked. The remote expansion tank will now serve as a check and system fill point. The plastic coolant recovery tank is not used when the remote expansion tank kit is installed, since this tank serves the same function. Remove and store the plastic recovery tank if it has been already installed.

NOTE: An air bleed petcock is located on the engine's heat exchanger. Open this petcock when filling the engine's coolant system to allow air in the exchanger to escape. Close tightly after all the air is removed.

POWER TAKE OFF SYSTEMS

OPTIONAL

POWER TAKE OFF ADAPTER

A power take off adapter can be attached to the generator backend. This adapter allows access to the full power of the engine for a variety of hydraulic and electrical accessories.

The 8.0 and 10.0 Kw generators produce 18hp at 1800 rpm (16hp at 1500 rpm).

The 11.5Kw produces 15hp at 1800 rpm (12hp at 1500 rpm)

The 15.0Kw generator produces 25hp at 1800 rpm (22hp at 1500 rpm).

This horsepower can be utilized either for generator AC output or to operate the power takeoff.

POWER TAKE OFF KITS
KIT #034786 FOR 12 STUD BT UNITS
KIT #037134 FOR 6 STUD BT UNITS

Contact your **WESTERBEKE DEALER** for additional information.

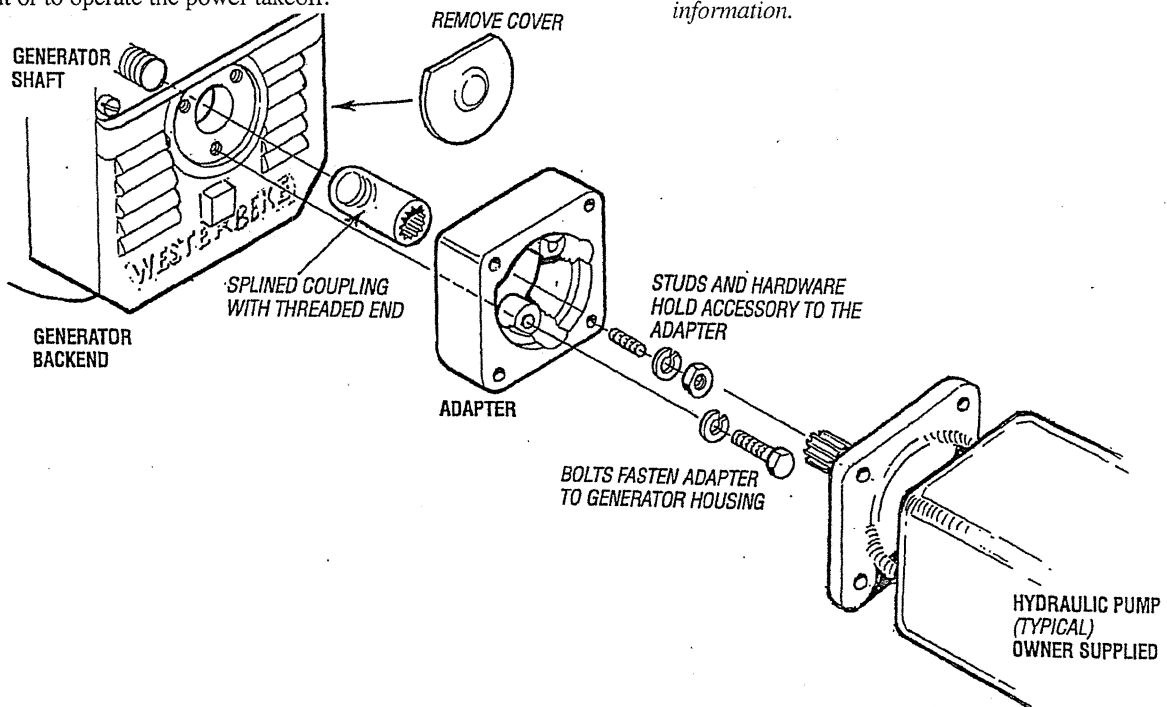

RAW WATER DISCHARGE HOSE

[When a siphon break is not required]

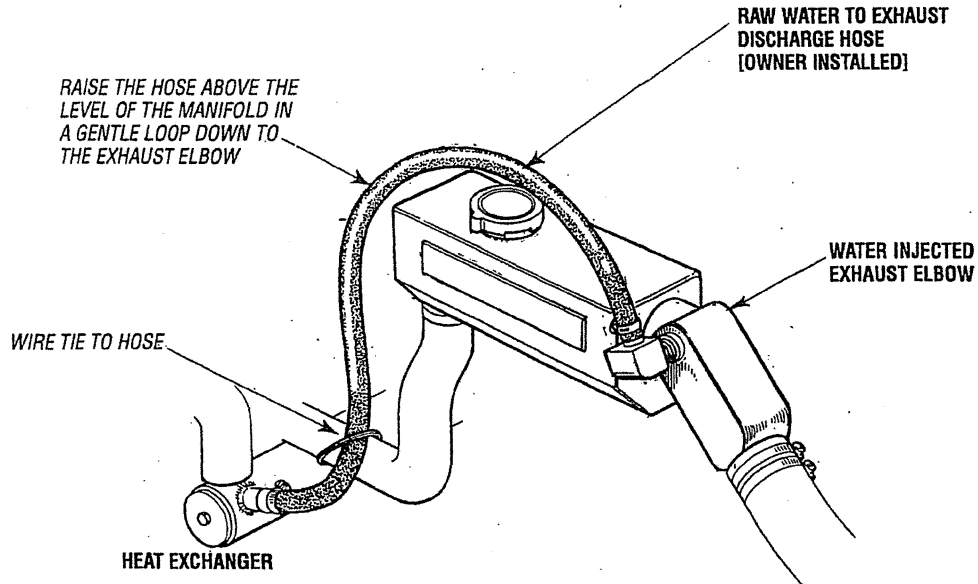

WHEN A SYPHON BREAK IS NOT REQUIRED

WESTERBEKE recommends that the hose (installer supplied) discharging raw water from the heat exchanger to the water injected exhaust elbow be looped above and down to the inlet fitting on the elbow. The hose can be secured by a plastic wire tie as illustrated.

ENGINE TORQUE SPECIFICATIONS

MAJOR BOLTS AND NUTS

Bolt or Nut	Diameter	Pitch	Width across flats	Clamp length	TORQUE		
					kg -m	ft - lb	N -m
Alternator Bracket	---	---	---	---	3.8-5.3	27-38	36.6
Back Plate	---	---	---	---	3.3-4.8	24-35	32.5
Connecting Rod Cap	M9	1.0	14	---	3.55±0.25	27±7.2	34.8±2.5
Coolant Pump	---	---	---	---	1.6±2.4	12-17	17.2
Coolant Pump Pulley	---	---	---	---	1.6±2.4	12-17	17.2
Coolant Temperature Sender	---	---	---	---	1.2±1.8	9-13	12.2
Coolant Temperature Switch	---	---	---	---	1.2±1.8	9-13	12.2
Crankshaft Pulley Nut	M18	1.5	27	---	17.5±2.5	127±18	172±25
Cylinder Head Bolt	M10	1.25	14	87	9±0.5	65 ± 4	88 ± 5
Delivery Valve Holder	---	---	19	---	4.5±0.5	32±5.4	44 ± 5
Engine Mounts	---	---	---	---	3.2±4.7	23-34	31.1
Exhaust Manifold	---	---	---	---	1.6±2.4	12-17	7.2
Flywheel Bolt	M12	1.25	19	29	13.5±0.5	98±4	132±5
Fuel Filter Assembly	---	---	---	---	4.6±6.8	33-49	44.7
Fuel Injection Nozzle Holder	M20	1.5	21	---	5.5±0.5	40±4.4	54±5
Fuel Injection Pipe Nut	M12	1.5	---	---	3±0.5	22±4	29±5
Fuel Leak-Off Pipe Nut	M12	1.5	18	---	2.75±0.25	20 ± 2	27±2.5
Fuel Solenoid Locknut	---	---	---	---	4.0±5.0	28.9±36.2	39.18
Glow Plug	M10	1.25	12	60	1.75±0.25	12±7.2	17.2±2.5
Glow Plug Connection Plate	M4	0.7	8	---	0.125±0.025	0.9±0.2	1.2±0.2
Intake Manifold	---	---	---	---	1.6±2.4	12-17	16.2
Main Bearing Cap Bolt	M10	1.25	17	81	5.25±0.25	38±2	51.5±2.5
Oil Filter	M20	1.5	---	---	1.2±0.1	8.7± 0.7	12±1
Oil Pan Bolt	M8	1.25	12	25	2.8±0.3	20.3±2.2	27±5.3
Oil Pan Drain Plug	M14	1.5	22	10	4.0±0.5	29±4	39±5
Oil Pressure Sender	---	---	---	---	1.2±1.8	9-13	12.2
Oil Pressure Switch	PT1/8	---	26	11	1±0.2	7.2±1.4	10±2
Pressure Relief Valve	M22	1.5	22	33	5.0±0.5	36±4	49±5
Rear Plate Bolt (stamping)	M8	1.25	12	16	1.15±0.15	8.3±1.1	11.3±1.5
Rear Plate Bolt (standard)	M12	1.25	17	28	6.5±1	47±7	64±10
Retaining Nut for Delivery Valve Holder Body	M16	0.75	19	---	3.75±0.25	27±2	37±2.5
Rocker Cover Bolt	M8	1.25	12	40	1.15±0.15	8.3±1.1	11.3±1.5
Rocker Shaft Bracket Bolt	M8	1.25	12	58	1.5±0.5	11±4	14.7±5
Sliding Sleeve Shaft	M10	1.25	14	29.5	3.6±0.6	26±4	35±6
Special Nut for Torque Spring Set	M12	1.0	17	---	2±0.5	14±4	20±5
Starter B Terminal	M8	1.25	12	---	1.1±0.1	8.0±7	10.8±1
Stop Solenoid	M30	1.5	36	---	4.5±0.5	32±5.4	44±5
Thermostat Housing	---	---	---	---	0.3-0.45	2-3	2.7
Thermoswitch	M16	1.5	17	31.5	2.3±0.4	16.6 ± 3	22.6 ± 4

SUGGESTED SPARE PARTS

WESTERBEKE MARINE DIESEL GENERATORS

CONTACT YOUR WESTERBEKE DEALER FOR SUGGESTIONS AND ADDITIONAL INFORMATION

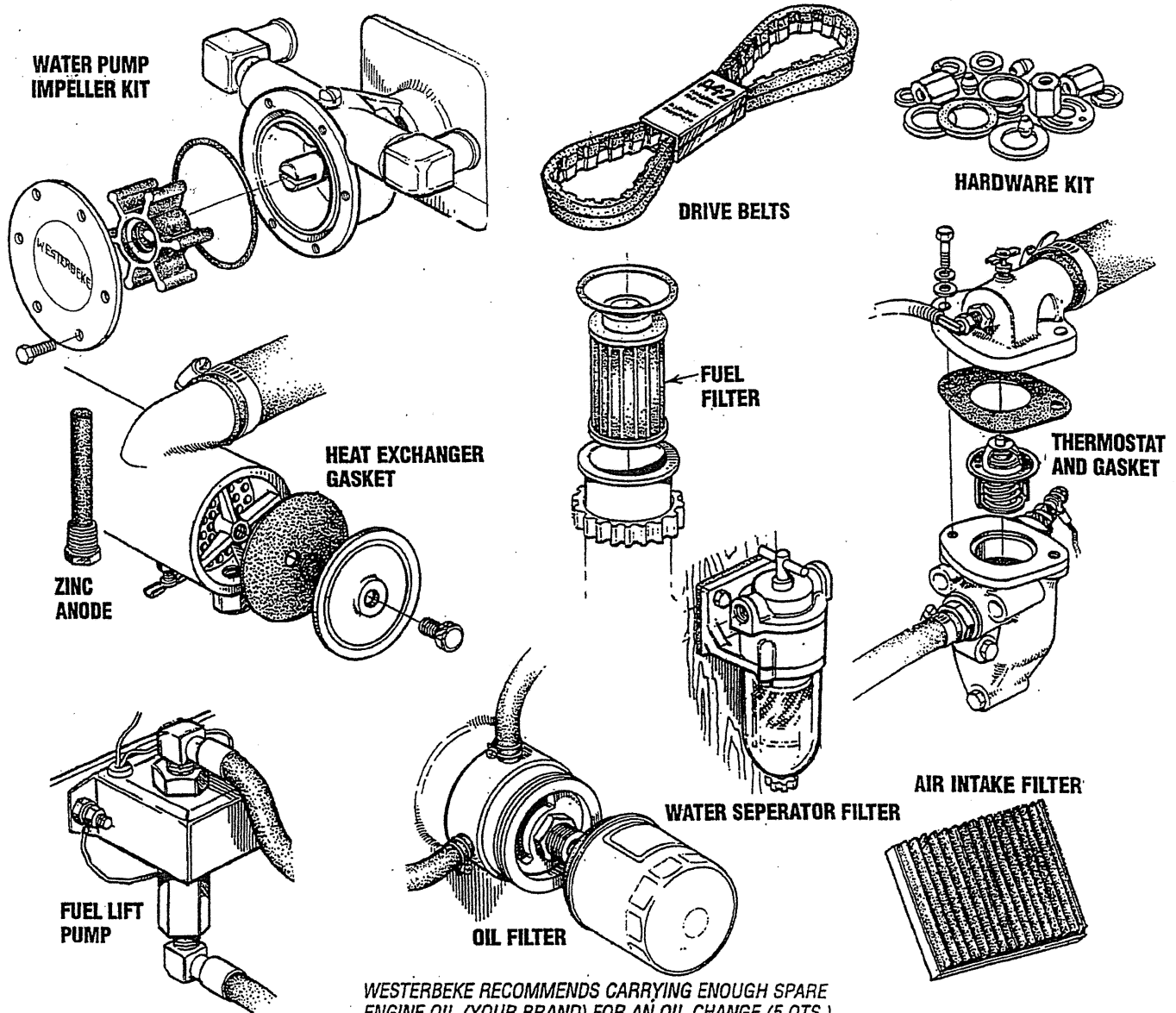

WESTERBEKE RECOMMENDS CARRYING ENOUGH SPARE ENGINE OIL (YOUR BRAND) FOR AN OIL CHANGE (5 QTS.) AND A GALLON OF PREMIXED COOLANT.

SPARE PARTS KITS

WESTERBEKE also offers two Spare Parts Kits, each packaged in a rugged hinged toolbox. Kit "A" includes the basic spares. Kit "B" is for more extensive off-shore cruising.

A Kit

- Impeller Kit
- Heat Exchanger Gasket
- Fuel Filter with Gasket
- Oil Filter
- Drive Belt
- Zinc Anodes

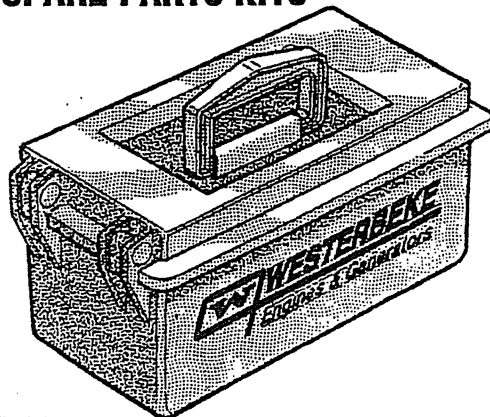

B Kit

- Impeller Kit
- Water Pump Repair Kit
- Thermostat Kit
- Zinc Anodes
- Complete Gasket Kit
- Heat Exchanger Gasket
- Injector
- Fuel Filter with Gasket
- Oil Filter
- Drive Belt

WESTERBEKE
Engines & Generators



WESTERBEKE CORPORATION • 150 JOHN HANCOCK ROAD
MYLES STANDISH INDUSTRIAL PARK • TAUNTON MA 02780
WEBSITE: WWW.WESTERBEKE.COM